

Elite **Steam Humidifier**



Installation, Operating and Maintenance Manual

Read And Save These Instructions



IMPORTANT WARNINGS



BEFORE INSTALLING OR HANDLING THE APPLIANCE PLEASE CAREFULLY READ AND FOLLOW THE INSTRUCTIONS AND SAFETY STANDARDS DESCRIBED IN THIS MANUAL AND ILLUSTRATED BY THE LABELS ON THE MACHINE.

This humidifier produces non-pressurized steam using electrodes immersed in the water contained in the plastic steam generator cylinder. The electrodes pass electrical current through the water, to produce steam.

The quality of the water used affects the ability of electrical current to pass through the water, so the appliance may be supplied with untreated water, **as long as this is drinkable and not demineralized**. (Use of softened water is not recommended.)

This appliance has been designed exclusively to directly humidify rooms or ducts, using the distribution system supplied. It is suitable for this purpose as long as: the installation, use and maintenance operations are carried out according to the instructions contained in this manual and on the labels applied internally and externally.

The conditions of the environment and the power supply voltage must comply with the specified values. All other uses and modifications made to the device which are not authorized by the manufacturer are considered incorrect. Liability for injury or damage caused by the incorrect use of the device lies exclusively with the user.

Please note that the machine contains powered electrical devices and hot surfaces. All service and/or maintenance operations must be performed by qualified personnel who are aware of the necessary precautions and are capable of performing the operations correctly. Disconnect the machine from the main power supply before accessing any internal parts. Local safety standards in force must be applied in all cases.

The humidifier is made up of metallic and plastic parts. All parts must be disposed of in accordance to local standards on waste disposal.

This product is warranted for 2 years from the date of installation, or 2 years and 1 month (see page 23 and warranty card) from the date of original shipment, whichever comes first. This warranty does not cover consumable parts, such as the steam cylinder. Full warranty information is on a separate registration card supplied with this appliance.

WARNING: Your humidifier requires water to operate. Do NOT mount it above materials or machinery that could be damaged if a leak occurs. General Filters, Inc. assumes no responsibility for consequential or inconsequential damage as a result of any leaks.

Table of Contents

| | |
|---|-----------|
| 1: REMOVE HUMIDIFIER FROM BOX AND OPEN | 4 |
| 2: MOUNTING THE HUMIDIFIER..... | 5 |
| POSITIONING | 5 |
| MOUNTING..... | 5 |
| 3: STEAM DISTRIBUTION | 6 |
| ROOM DISTRIBUTION | 6 |
| DUCT DISTRIBUTION..... | 7 |
| STEAM HOSE INSTALLATION..... | 7 |
| 4: PLUMBING | 9 |
| CONNECT WATER DRAIN..... | 9 |
| CONNECT WATER FEED | 9 |
| 5: POWER WIRING | 10 |
| 6: CONTROLS WIRING..... | 11 |
| MOUNT THE HUMIDISTAT..... | 11 |
| MOUNT 12500 AIR PRESSURE SWITCH (DS-20 ONLY) | 11 |
| CONNECT HOSES. CONNECT HOSE TO SUPPLY PLENUM PROBE. TRIM HOSE TO LENGTH AND CONNECT TO HIGH PRESSURE INLET TOWARD REAR OF SWITCH. CONNECT RETURN PLENUM PROBE TO LOW PRESSURE INLET TOWARD FRONT OF SWITCH. | 11 |
| WIRE THE CONTROLS | 12 |
| 7: START-UP AND SHUT-DOWN | 13 |
| FIRST START-UP | 13 |
| STARTING THE UNIT | 13 |
| SHUT-DOWN | 14 |
| 8. OPERATING PRINCIPLE AND OTHER FUNCTIONS..... | 15 |
| OPERATING PRINCIPLE | 15 |
| 9. ALARMS, TROUBLESHOOTING | 16 |
| 10. MAINTENANCE AND SPARE PARTS..... | 18 |
| REPLACING THE CYLINDER | 18 |
| MAINTENANCE OF THE OTHER HYDRAULIC COMPONENTS | 18 |
| CLEANING THE FILL VALVE..... | 18 |
| CLEANING THE DRAIN VALVE..... | 19 |
| HYDRAULIC PARTS | 19 |
| SPARE PARTS..... | 20 |
| 11. WIRING DIAGRAM..... | 21 |
| 12. TECHNICAL SPECIFICATIONS | 22 |
| DIMENSIONS AND WEIGHTS..... | 22 |

1: Remove Humidifier From Box And Open

Twist GeneralAire brand badge on the front cover of the cabinet to uncover the hidden capture screw underneath the right side.

Remove capture screw using a phillips screwdriver. (take care not to lose the screw)

Lift cabinet front cover upward about 1" and then pull forward to remove.

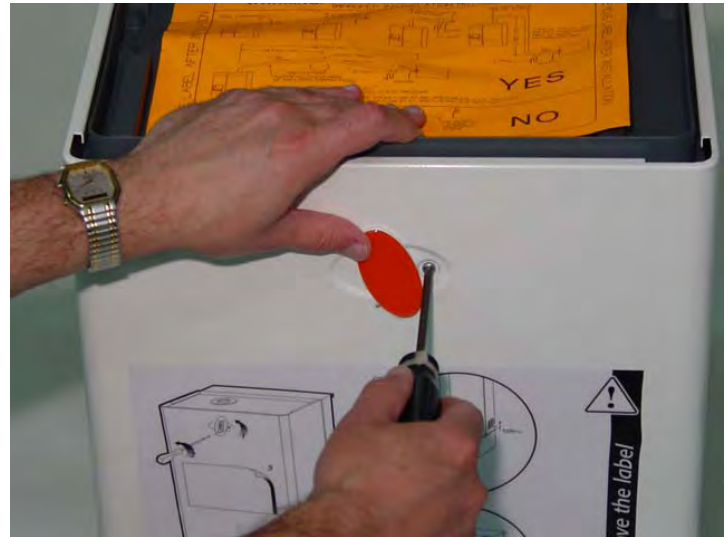

Your *Elite Steam* humidifier will consist of:

For duct mounted applications:

- 1 - Steam humidifier unit
- 1 - Duct steam nozzle
- 6' - 7/8" ID steam hose
- 2 - Steam hose clamps
- 7' - 5/16" ID condensate hose
- 1 - Condensate hose clamp
- 1 - 800 UST Saddle valve kit
- 1 - Wall / Duct Mount Humidistat
- 1 - 12500 Air Pressure Switch
- 1 - Water supply tube kit
- 3 - Screws and anchors
- 1 - Fill connector
- 1 - 10' coil low voltage wire

For room mounted applications:

- 1 - Steam humidifier unit with blower attached
- 1 - 800 UST Saddle valve kit
- 1 - Wall / Duct Mount Humidistat
- 1 - Water supply tube kit
- 3 - Screws and anchors
- 1 - Fill connector
- 1 - 10' coil low voltage wire



IMPORTANT: BEFORE beginning installation:

Check for shipping damage to cartons. Mark the shipping waybill accordingly.
Open cartons and check for any hidden damage. Mark the shipping waybill accordingly.
Check packing slip to insure all items have been received. Notify General Filters, Inc. within one week of any shortages or damaged parts.

2: Mounting The Humidifier

Positioning

The humidifier unit should be mounted as close as possible to the steam distributor nozzle or blower unit to minimize steam hose length and condensate losses.

The unit has been designed for wall-mounting, and the wall must be able to support the weight of the unit in normal operating conditions (See bottom of page).

The metal cabinet of the humidifier heats up during operation, and the rear part in contact with the wall may reach temperatures of over 140°F. Make sure the humidifier is mounted level and plumb, and that the minimum clearances, as shown at right, are maintained to allow room for maintenance operations and ventilation.

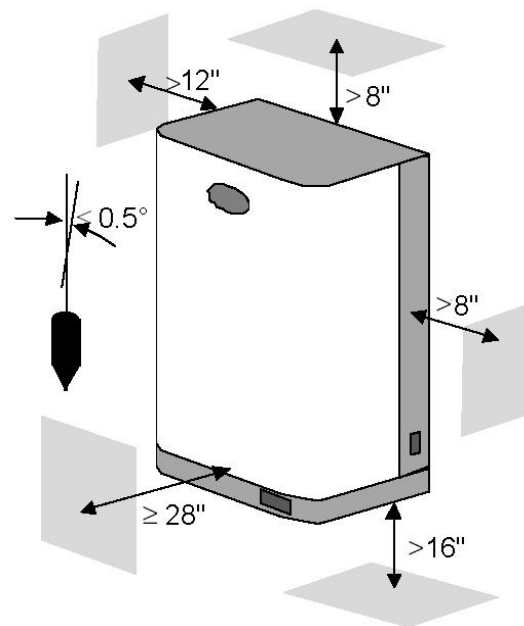

Mounting

The humidifier must be wall-mounted using three screws: two upper screws, for fastening the support bracket, and one lower, central screw, to fasten the unit into place. To the right is the template for the mounting holes.

Fasten the bracket supplied with the humidifier to the wall (see below); **making sure that it is level.** If the unit is to be mounted to a block wall, use the plastic screw anchors (5/16") and screws (3/16" x 2") supplied.

Hang the humidifier on the bracket using the mating bracket located on the top edge of the back of the humidifier. Fasten the humidifier to the wall using the central hole in the rear part of the base; this can be easily reached from underneath the unit.

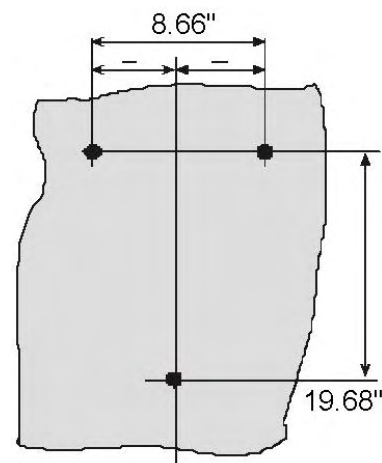

Height: 24-3/8"
Width: 14-1/8"
Depth: 10-1/4"

Weight dry: 29.7 lbs.
Weight wet: 36.4 lbs.

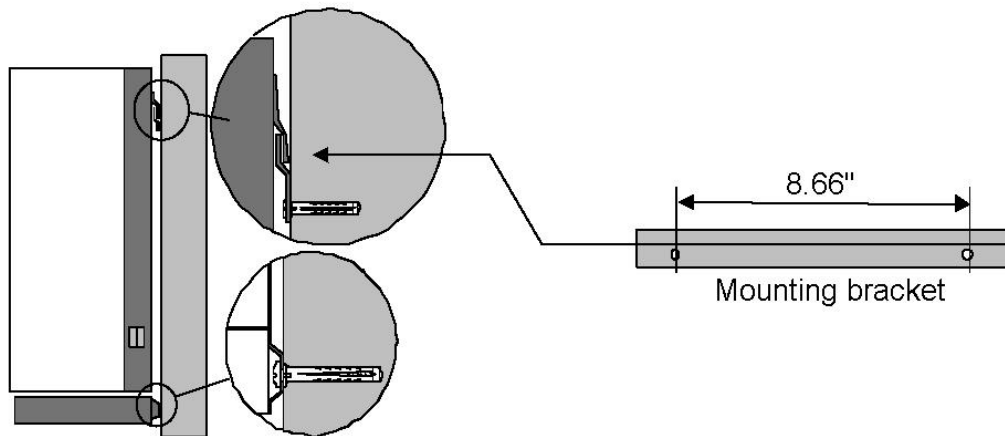

3: Steam Distribution

Room Distribution

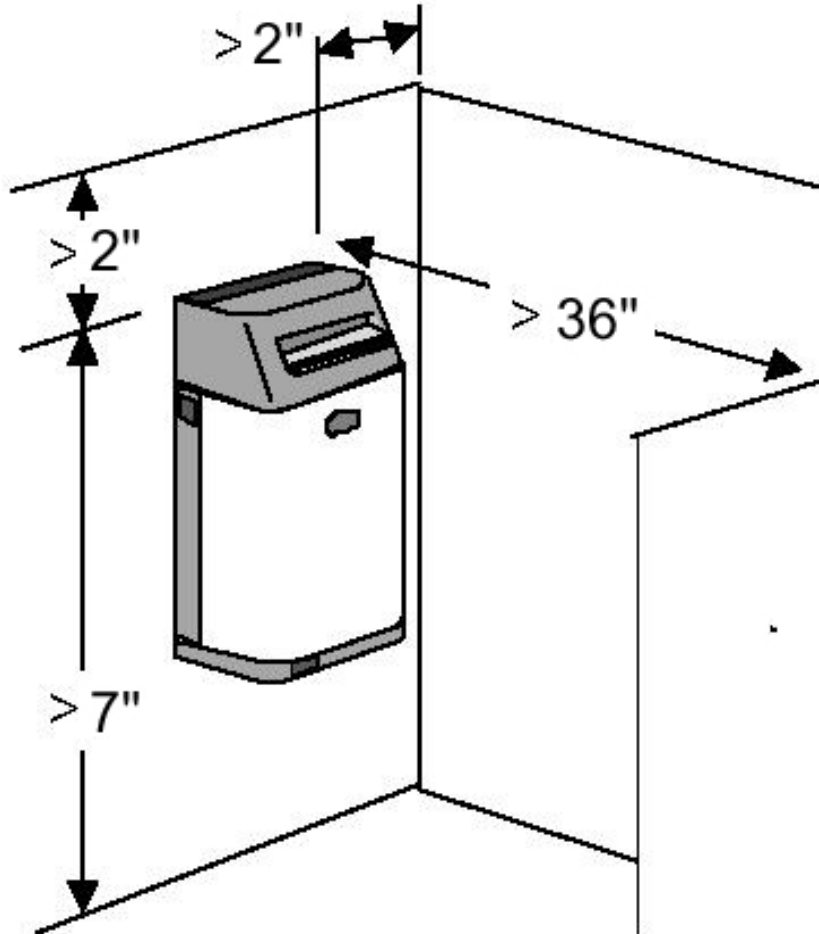

The room distribution unit is used to distribute the steam directly into the room, and is supplied premounted to the top of the humidifier.

The drawing shows the minimum distances required to prevent humidified air from coming into contact with persons, or surfaces before the steam has been totally absorbed by the air.

Installation, Operating and Maintenance Manual

Duct Distribution

If a duct steam distribution nozzle is to be used, selected an accessible location on the duct, allowing at least 18" of straight duct (no elbows or obstructions) after the point where the nozzle will be installed and the clearances can be maintained as per the following drawings.

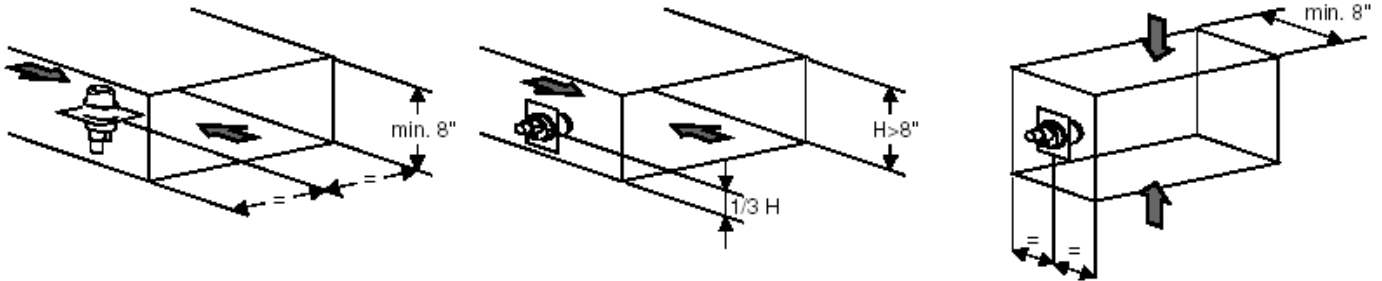

To mount the steam distributor nozzle, cut or drill a 2-1/2" hole in the duct. Apply caulk to the mounting plate of the nozzle. Attach the nozzle to the duct using 4 #10 sheet metal screws (supplied). Nozzle must be level with condensate outlet to bottom.

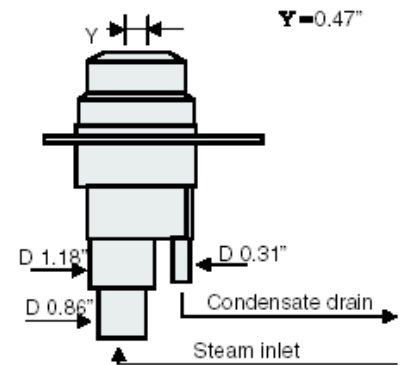
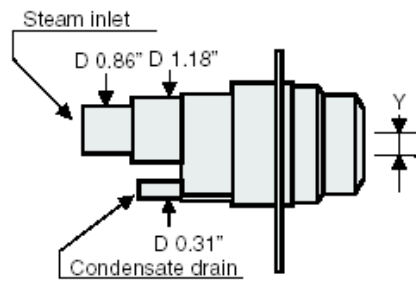
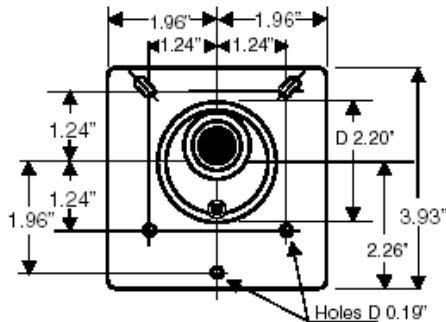

Steam Hose Installation

The humidifier must be connected to the distributor nozzle using the GeneralAire hose supplied or other hose suitable for use with steam and condensate. The use of unsuitable tubing may cause weakening and cracking and consequently steam leaks.

Installation of the steam hose is absolutely critical. 95% of all operational problems are traced back to improper hose installation.

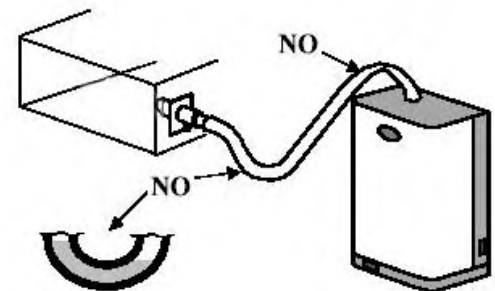

Steam must flow through the hose, and condensate must flow back. Avoid any kinks, sags or areas where condensate can become trapped as it will impede the free flow of steam, putting pressure on the humidifier cylinder.

The steam hose must slope 20% up and away from the humidifier or 5% down and away.

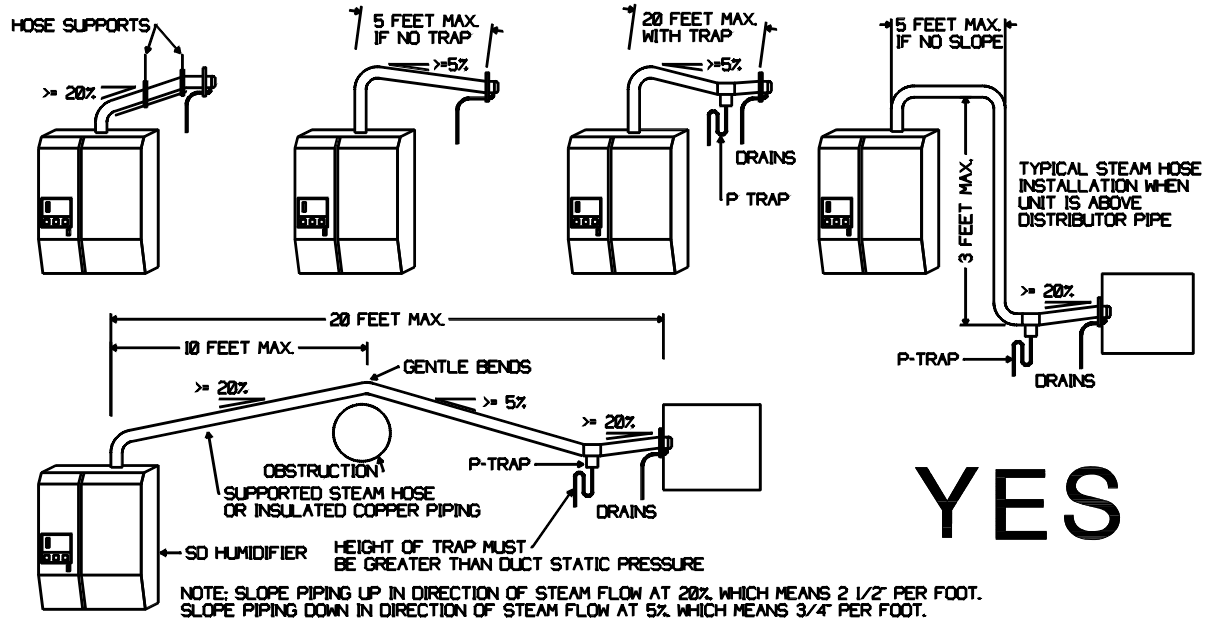

YES

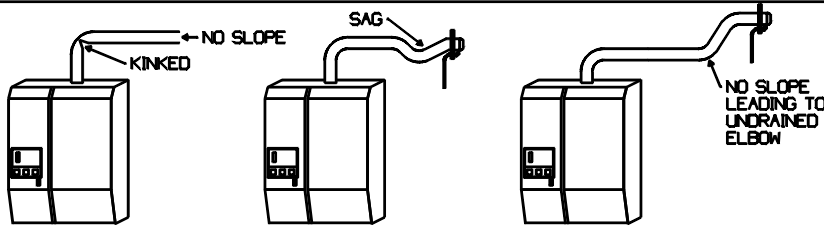

NO

If necessary, support the steam hose using braces or other supports. **DO NOT** try to pipe the steam to two different ducts or air handlers.

The condensate hose should be trapped as shown in the two drawings above. This is to prevent steam from flowing through it. The condensate is wasted, either to the nipple on top of the humidifier, or to a separate drain. **DO NOT** put condensate into the humidifier fill cup.

Hose clamps are provided for the 7/8" I.D. steam hose as well as for the 5/16" condensate hose. **DO NOT** reduce the size of the steam hose, use valves or otherwise restrict the free steam flow.

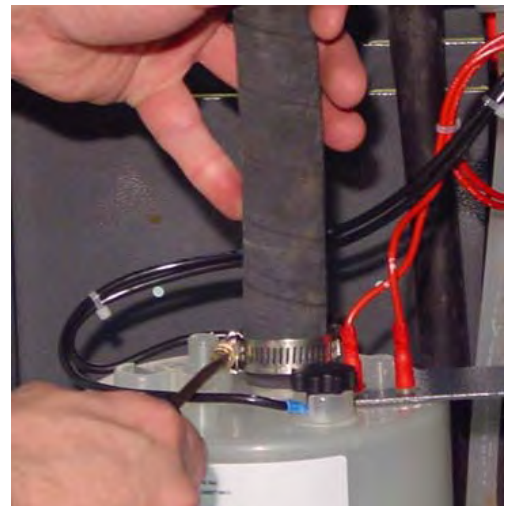

WARNING: the length of the steam hose should be less than 12 feet.

4: Plumbing

Connect Water Drain

The humidifier periodically drains some hot water to remove mineral build-up in the steam cylinder. This water is generally in the range of 140 to 200°F, so the drain piping must be CPVC or copper.

The drain line should be 1-1/2" diameter CPVC. Slip the 1-1/2" pipe over the drain outlet on the bottom of the humidifier as shown at right. Do not glue to the humidifier.

A trap must be used in the drain line directly below the humidifier to prevent flash steam from rising into the humidifier unit and condensing on components.

WARNING: Failure to install a drain trap as instructed will void the warranty.

Instant maximum drain water flow = 0.40 gpm



Connect Water Feed

A plastic and brass quick connect fitting is supplied for connection of the water feed line. This fitting includes a 1/4" O.D. compression fitting which mates to standard 1/4" O.D. plastic or copper tubing.

Inside the fill valve connection is a plastic strainer which must be removed for periodic maintenance. Make sure that your installation will allow the plastic fitting to be removed for maintenance.

WARNING: Hand tighten only.

DO NOT USE DEMINERALIZED WATER.

Instant maximum feed water flow = 0.30 gpm

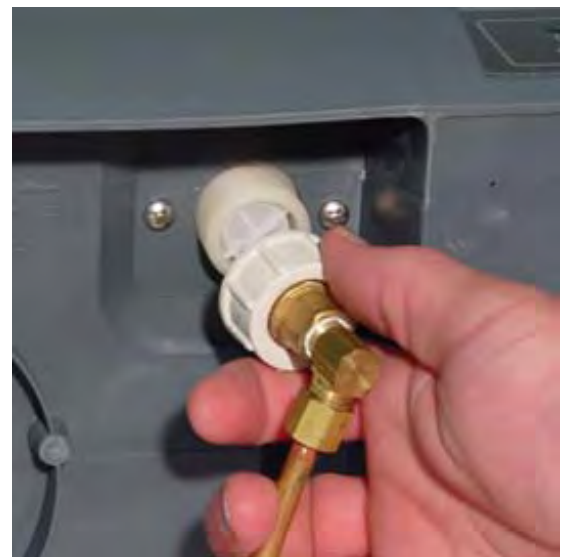

5: Power Wiring

Feed power wiring through strain relief in bottom of humidifier and tighten around wiring cable.



Connect power wires into terminals N and L. A green/yellow ground terminal (which is also the chassis ground) is provided for connection of the ground wire.



| Power supply | Rated specifications | | | | | |
|---------------------------|----------------------|-------------------|--------------------------|-----------|-------------------------------|-------------------|
| Voltage (1) (V - Type) | current (2) (A) | power (2) (kW) | Steam output (lbs/hr) | wire size | power fuses (4) (A / type) | wiring diagram |
| 230 – 1 N | 10.4 | 2.40 | 7 | 12 AWG | 15A / quick blow | See end of manual |

6: Controls Wiring

Mount The Humidistat

Please refer to the installation Instructions included with the Humidistat.

Mount 12500 Air Pressure Switch (DS-20 Only)

Mount Air Flow Switch on a vertical surface. Switch must be oriented vertically with the hose connections pointed down. Do not mount switch on or in warm air plenum. Use care when locating mounting holes so as not to damage furnace electronics, fuel lines, combustion chamber, etc.

Mount Plenum Probes. Select locations on supply and return plenums so length of supplied hose will be sufficient and does not kink. Drill $\frac{1}{4}$ " hole and insert long end of probe into duct. Use two sheet metal screws to secure probe.

Connect hoses. Connect hose to supply plenum probe. Trim hose to length and connect to high pressure inlet toward rear of switch. Connect return plenum probe to low pressure inlet toward front of switch.

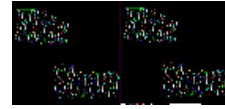

Wire The Controls

Two pigtail wires are provided inside the electrical compartment of the humidifier. This “AB” to “AB” circuit is the low-voltage control for the humidistat and air pressure switch. The humidifier will run when the AB-AB Circuit is completed.

24 volt A.C. to power the E1 Humidistat may be pulled from the “G” and “GND” terminals.

The AB-AB circuit is completed through the 12500 Pressure Switch (“NO”, “C” terminals) and the E1 Humidistat (“OUT” terminals).

If it is desired for the humidifier to activate the heating fan during a call for humidity use the second wiring scheme below.

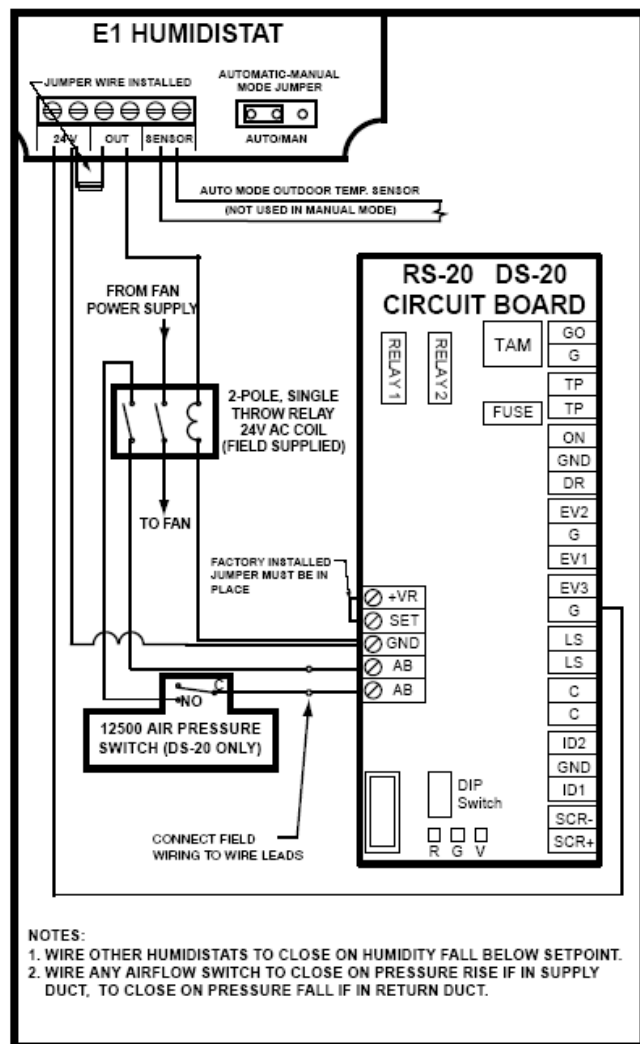
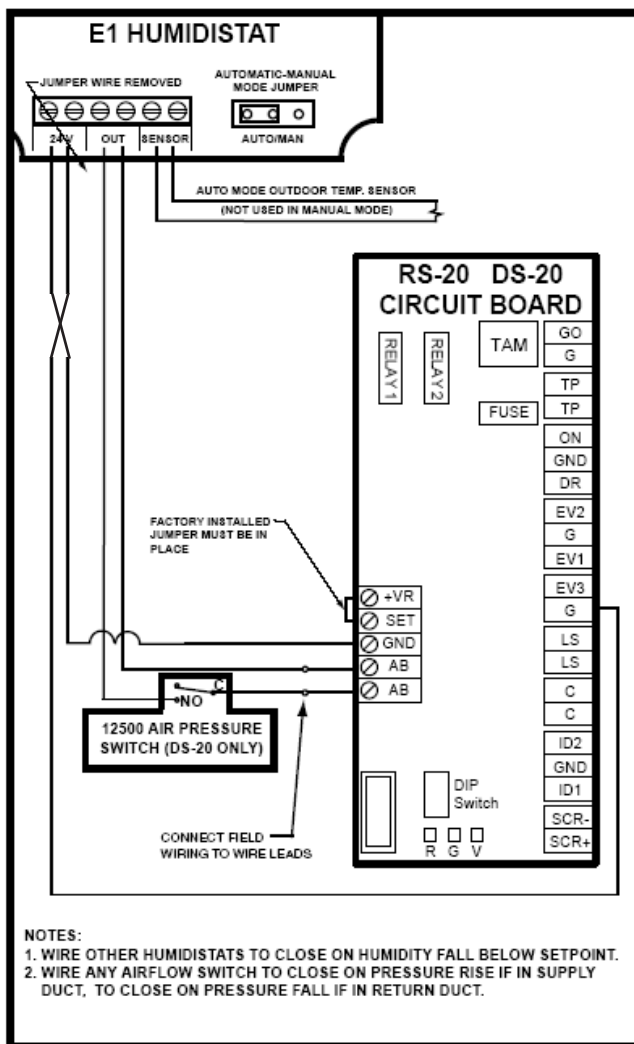

| terminal | function | electrical specifications |
|----------|---|---|
| +VR | Enabling jumper | external N/O contact; $R_{max}=50$; $V_{max}=10Vdc$; $I_{max}=1mA$ |
| SET | | |
| AB | Input from humidistat remote enabling input | external N/O contact; $R_{max}=50$; $V_{max}=24Vdc$; $I_{max}=10mA$ |
| AB | | |
| G | 24V AC power supply for E1 Humidistat and relay | Output $V_{max}=24Vac$; $LOAD_{max}=500mA$ ac |
| GND | | |

7: Start-Up And Shut-Down

Important Warnings:

Before starting, check that the humidifier is in perfect condition, that there are no water leaks and that the electrical parts are dry;

Do not connect power if the humidifier is damaged or even partially wet;

When installation is completed, flush the supply tubing for several minutes by piping water directly into the drain, without sending it into the humidifier. This will eliminate any scale or construction dirt that may cause foam when boiling.

Before starting the humidifier, check the following:

The water, electrical and steam distribution connections have been made according to the instructions contained in this manual;

The water shut-off valve to the humidifier is open;

The external main power fuses or breakers are installed and intact;

All wiring connections to the unit and inside the unit are tight;

The pigtail control wires are connected properly to the humidistat and air flow switch and that these are both closed indicating a demand for humidity and air flow in the duct;

The steam hose is clear and properly sloped;

The condensate return hose from the distributor is installed, trapped and open to drain;

The drain tubing is correctly connected, trapped and open to drain;

First start-up

When first starting the unit with a clean empty cylinder, the humidifier will operate using a special start-up routine designed to concentrate the minerals in the water for maximum efficiency. If the water is very good (low mineral content) this process may take up to several hours before the full rated production of steam is reached.

Starting the unit

On the right side, rear of the humidifier cabinet are two rocker switches. One is marked I and O; this is the On/Off switch (I=On, O=Off). Next to it is the manual drain switch.

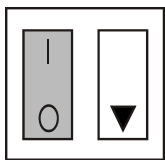

to be sure

To start the humidifier, simply press the top of the On switch (I). If the unit does not start operating, then check the control devices wired between the pigtail control wires they are closed, completing the control circuit.

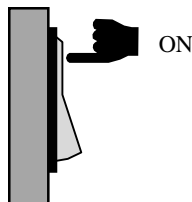

Once started, the LEDs on the control panel at the bottom front of the humidifier will glow to indicate operation

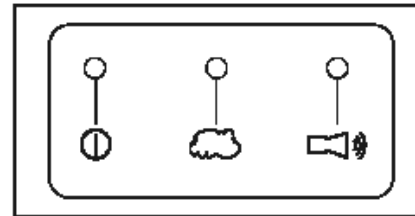

| LED | Position | Means |
|--------|----------|--|
| Green | Left | Power on |
| Yellow | Center | Humidification in progress |
| Red | Right | Signals and alarms. These are indicated by specific flashes. |

Sequence Of LED Flashes On Start-Up

On start-up, the humidifier performs a sequence of flashes of the LEDs on the front panel. Please note that the green LED remains on for the entire time the machine is on, irrespective of the operating status. The sequence consists of the following operations:

1. Power connected: the yellow and red LEDs remain off for 1 second;
2. Initialization: the yellow and red LEDs flash a number of times to indicate the version of the program that the board is configured with; this occurs once each time the machine is started;
 - a. First the yellow LED - the number of flashes indicates the tens (0=no flash);
 - b. Then the red LED - the number of flashes indicates the units (0=no flash); **example:** version 1.1: 1 flash of the yellow LED, then 1 flash of the red LED;
 - c. Once the sequence of flashes corresponding to the unit is completed, the LEDs remain off for 3 seconds, followed by the start of operation.
3. Operation: the humidifier starts operation; the yellow LED indicates that production is in progress, as shown by the following table:

| Yellow LED | Production |
|------------|------------|
| Off | 0% |
| 1 flash | 1% to 19% |
| 2 flashes | 20% to 29% |
| 3 flashes | 30% to 39% |
| ... | ... |
| 9 flashes | 90% to 99% |
| Always on | 100% |

Remark: the transient production is signalled by short flashes: on and off twice in 1 second; each sequence of flashes repeats continuously and, between one sequence and the next one, the yellow LED stays off for 3 seconds.

Indication Of An Alarm

When an alarm occurs, the red LED starts to flash. The number of the flashes followed by a pause indicates specific alarms. See **ALARMS, TROUBLESHOOTING**.

Shut-Down

During seasonal shut-down or shut-down for maintenance, the humidifier should be placed out-of-service.

Installation, Operating and Maintenance Manual

If during a shut-down **the cylinder needs to be emptied**, (which is recommended for seasonal shut down) press the drain button (down arrow) and hold until the water has been completely emptied, before disconnecting power from the unit.

In the event of a malfunction of the drain valve, the cylinder can be emptied by lifting it from the bottom connection and slowly pouring the water into the drain pan.

Press the bottom of the On/Off rocker switch (O) and check that the LEDs on the display panel are all out.
open the main power switch to the humidifier;
close the water shut-off valve to the humidifier.

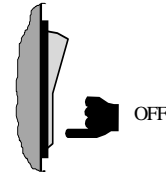

8. Operating Principle And Other Functions

Operating principle

On a call for humidity, a power contactor closes and sends power to the electrodes (11) in the plastic cylinder (10). After a short delay, the fill valve (1) opens and water flows into the fill cup (3 to 7), covering the conductivity probes (6).

The controller reads the water conductivity and remembers it. Water then flows through the tubing (4) and into the bottom of the cylinder (12) by gravity. As it rises over the electrodes (11), electric current begins to flow through the water and the water warms. Eventually the water begins to boil into steam, which exits the cylinder (9) into the steam hose and then into the air duct. The steam output is directly proportional to the amount of electrode covered by water. If the amperage rises too high, the controller will open the drain valve (14) and drain off some water. As water is boiled off, the fill valve (1) will open and replace it. As water is boiled off, mineral will begin to build up in the cylinder, so periodically the controller will open the drain valve (14) and drain some of the mineral laden water away and replace it with fresh water. If the water rises too high, or foaming occurs, this is detected by the cylinder full electrodes (8).

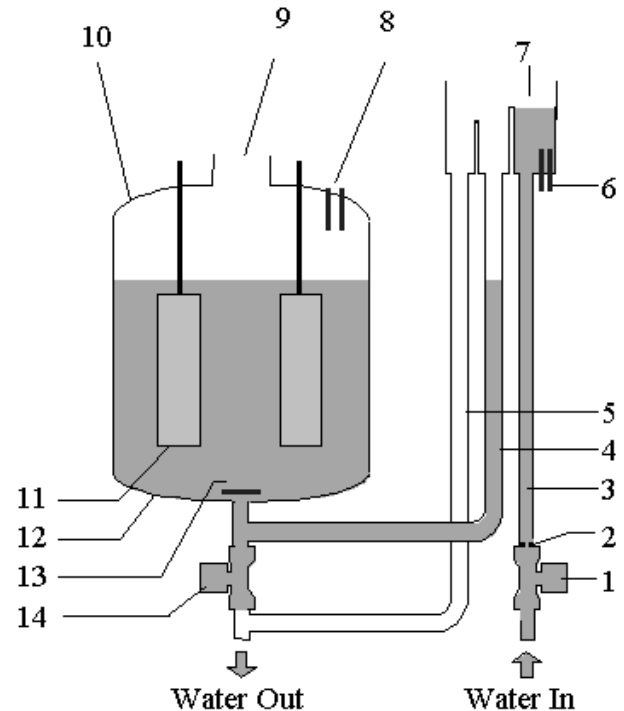

Anti-foam procedure

Some types of supply water foam during operation. When the humidifier detects the presence of foam, a special drain/fill procedure is activated to eliminate the foam. The procedure consists of repeated draining, and in more critical situations complete draining of the cylinder.

Automatic draining of the cylinder for extended shut-down

If the humidifier remains powered but there is no call for humidity for a period of more than 7 days, the water contained inside the cylinder is completely drained. This function prevents the corrosion and rusting of the electrodes.

9. Alarms, Troubleshooting

Alarms are indicated on the front display panel by a sequence of flashes of the red alarm LED. In the event of more than one alarm, these are indicated in sequence. Even if no longer active, the alarm status continues to be displayed by the flashing of the LED and the operation of the humidifier is stopped while the alarm is still present. To clear the inactive alarms, the humidifier must be turned off, and then on again. **Active alarms cannot be reset by restarting the machine.**

LED flash modes: slow flashes - 1 flash every 2 seconds; quick flashes - 2 flashes per second; the signals are repeated continuously, and the LED stays off for 3 seconds between one signal and the next.

| Display | Causes | Solution | Action |
|---|---|--|-----------------|
| 2 quick flashes red LED | Current overload in the electrodes; probable fault in the electrodes or water temporarily too conductive (especially on re-start after a brief pause) | Drain part of the water and re-start | Total shut-down |
| 3 quick flashes red LED | High level is indicated but no amperage draw is present | With the machine off and disconnected from the main power supply, check the condition of the cylinder and the electrical connections | Total shut-down |
| 2 slow flashes red LED | End of cylinder life | Turn the machine off and replace the cylinder | Signal only |
| 3 slow flashes red LED | No water | Check that the supply water tubing to the humidifier and the internal tubing are not blocked or bent and that there is proper pressure; Check the operation of the supply valve; Check that the steam outlet does not have excessive back-pressure, preventing the flow of water into the cylinder by gravity; Check that the steam outlet hose is not choked or that there are pockets of condensate | Total shut-down |
| 4 slow flashes red LED | Excessive reduction in steam output | End cylinder life or alternatively water with excessive foam | Total shut-down |
| 5 slow flashes red LED | Drain malfunction | Check the water drain circuits and the correct operation of the drain valve | Total shut-down |
| 6 slow flashes or 3 quick flashes red LED | Internal memory error | Contact the Dealer | Total shut-down |
| 9 slow flashes | Cylinder full with humidifier off-duty | Turn off the machine and check whether the full electrovalve leaks or there is some condensate entering the cylinder from the steam distributor | Total shutdown |

Installation, Operating and Maintenance Manual

Troubleshooting table

| Problem | Causes | Solution |
|--|--|--|
| The humidifier does not turn on | <ol style="list-style-type: none"> 1.No electrical power; 2.On/Off switch of the humidifier in Off position (O); 3.Improper connection; 4.Blown fuses; 5.Transformer fault; 6.Humidistat or air flow switch not closed | <ol style="list-style-type: none"> 1.Check the external fuses and breakers and for power at the humidifier; 2.Turn the On/Off switch On (I); 3.Check that the power wires are properly inserted in the terminal block; 4.Check the condition of fuses f1/f2/f3; 5.Check that the voltage across the secondary winding of the transformer is 24vac 6. Jump out airflow & humidistat |
| The humidifier does not start operation | <ol style="list-style-type: none"> 1.Humidistat or air flow switch open; 2.The humidistat has not been connected correctly; 3.Humidistat fault | <ol style="list-style-type: none"> 1.Fix or replace humidistat or air flow switch; 2.Check the external wiring |
| The humidifier fills with water without producing steam | <ol style="list-style-type: none"> 1.Too much backpressure in steam hose; 2.Cylinder drain screen blocked; 3.Lime scale in the fill cup; 4.Drain valve malfunction | <ol style="list-style-type: none"> 1.Check that the steam outlet pipe is not bent or choked; 2.Clean the filter; 3.Clean the fill cup; 4.Check for the presence of 24vac at the drain electrovalve and/or replace drain electrovalve |
| Breaker opens | Circuit breaker is under-rated | Check that the thermal-magnetic overload switch is rated for a current of at least 1.5 times the rated current of the humidifier |
| The humidifier wets the duct | <ol style="list-style-type: none"> 1.The distributor is not installed correctly; 2.Humidifier over-sized; 3.Humidifier active when the fan in the duct is off | <ol style="list-style-type: none"> 1.Check that the steam distributor is installed correctly; 2.Change humidifier model; 3.Check the connection and condition of the airflow switch |
| The humidifier wets the floor below | <ol style="list-style-type: none"> 1.The humidifier drain is blocked; 2.The supply water or overflow circuit has leaks; 3.The steam outlet pipe is not properly fastened to the cylinder | <ol style="list-style-type: none"> 1.Clean the drain in the bottom tank; 2.Check the entire water circuit; 3.Check the fastening of the pipe clamps on the steam outlet |

10. Maintenance And Spare Parts

Replacing The Cylinder

WARNING: the cylinder may be hot. Allow it to cool before touching it or use protective gloves.

To access the cylinder:

- Completely drain the water contained in the cylinder (see **Shut-down**);
- Turn the humidifier off and open the external disconnect;
- Open and remove the cover (see **Removal and reassembly of the front cover**);
- Remove the steam hose from the cylinder outlet;
- Disconnect the electrical connections from the power and high level electrodes;
- Unlock the cylinder from its holding arm and lift it up to remove it;
- Insert the new cylinder in the humidifier by performing the previous operations in reverse.
(Make sure electric connection is tight, failure to do so may cause equipment damage, fire, or bodily injury.)

Maintenance Of The Other Hydraulic Components

WARNINGS:

- **When cleaning the plastic components do not use detergents or solvents;**
- **Scale can be removed using a solution of 5% phosphoric acid and then rinsing with water (Lime-A-Way or CLR may also be used).**

The steam humidifier has just one part that requires periodical replacement: **the steam production cylinder**. This operation is necessary when mineral deposits that form inside the cylinder prevent the sufficient passage of current. This situation is displayed by the control with an alarm signal. The frequency of this operation depends on the supply water: the higher the content of mineral, the more frequently the cylinder will need replacing.

Cleaning The Fill valve

After shutdown and removal of the steam cylinder, shut off the water supply to the humidifier, disconnect the water supply and remove the fill valve from the humidifier.

Remove the inlet strainer by reaching up into the fill valve inlet with a pair of needle nose pliers and pulling out the strainer by its tab. Clean the fill valve and inlet strainer using the same solution as used to clean the steam humidifier, but **DO NOT** soak the solenoid coil in fluid. Reinstall the fill valve.

WARNING: When cleaning the fill valve, do **NOT** poke or probe flow regulator with any object which may enlarge the orifice. The flow regulator must meter water flow precisely or shortened cylinder life may result.

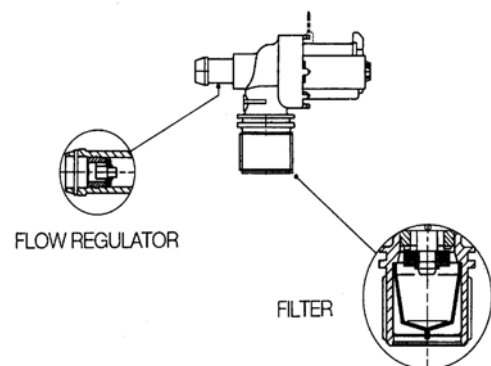

Installation, Operating and Maintenance Manual

Cleaning The Drain Valve

Remove the drain valve group and disassemble it. Clean all parts in the same way as the fill valve, reassemble and reinstall.

After cleaning and reassembly, restart your humidifier according to the Startup Instructions contained in this manual.

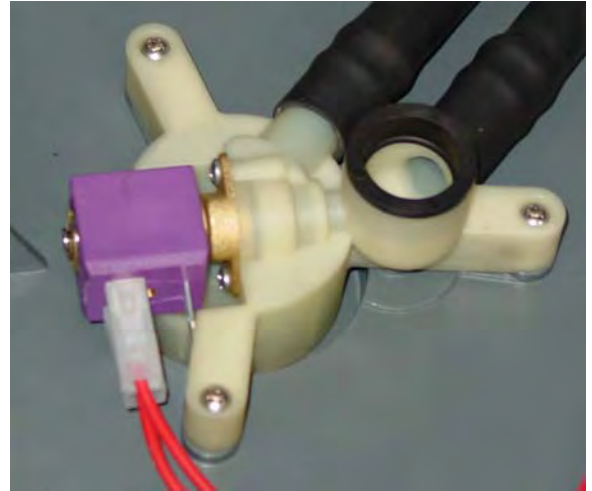

Hydraulic Parts

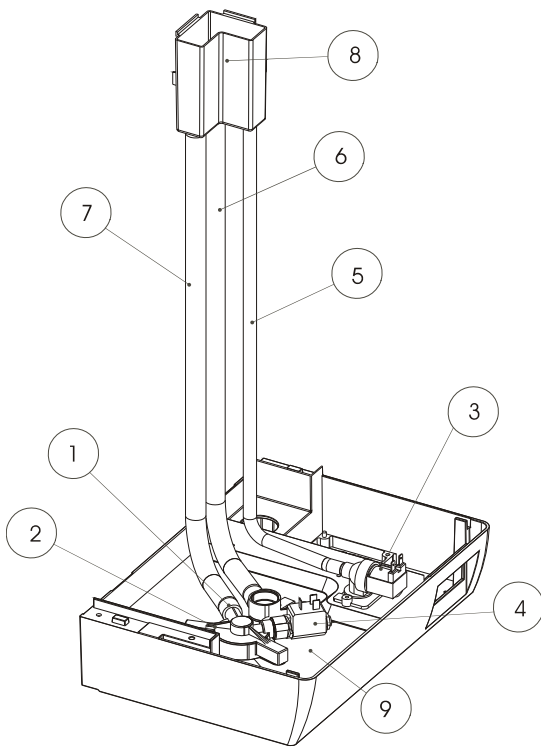

| No. | Description |
|-----|--|
| 1 | Fastening o-ring for s/d (supply - drain) manifold |
| 2 | Supply/drain manifold |
| 3 | Water fill valve |
| 4 | Drain valve |
| 5 | Fill cup supply hose |
| 6 | Cylinder supply hose |
| 7 | Overflow hose |
| 8 | Fill cup with conductivity probes |
| 9 | Base / drain pan |

See spare parts list on page 20

Clean the drain pan and fill cup of any deposits and check that the water flows freely from the fill cup to the drain.

Check that there are no blockages or solid particles and that the conductivity measuring electrodes are clean. Remove any impurities and rinse.

Fuses in the auxiliary circuits

The dimensions of these are 10.3x38 mm and are contained in cartridge-type fuse holders; to check the condition of the fuses, check continuity using a tester. Use fuses with the settings indicated in the following table.

| | |
|-------------------|--------------|
| Fuses 1- 2 | 1A fast-blow |
| Fuse 3 * | 2A slow blow |

* 5 x 20 mm, only on the control board.

Spare parts

| Description | Code |
|--------------------------------------|---------|
| Duct Steam Nozzle | 20-1 |
| Steam Hose | 20-2 |
| Condensate Hose | 20-3 |
| Fill Connector | 20-4 |
| Fill Cup | 20-5 |
| Drain Valve | 20-6 |
| Internal Tubing Kit | 20-7 |
| Power Transformer 208-230/24v. | 20-8 |
| Control board with LED support panel | 20-9 |
| Fill Valve | 20-10 |
| Steam Cylinder | 20-14 |
| Self Tapping Saddle Valve Kit | 800-UST |
| Water Supply Tubing Kit | 747-38 |
| Humidistat | H-86 |
| Air Pressure Switch | 12500 |

11. Wiring Diagram

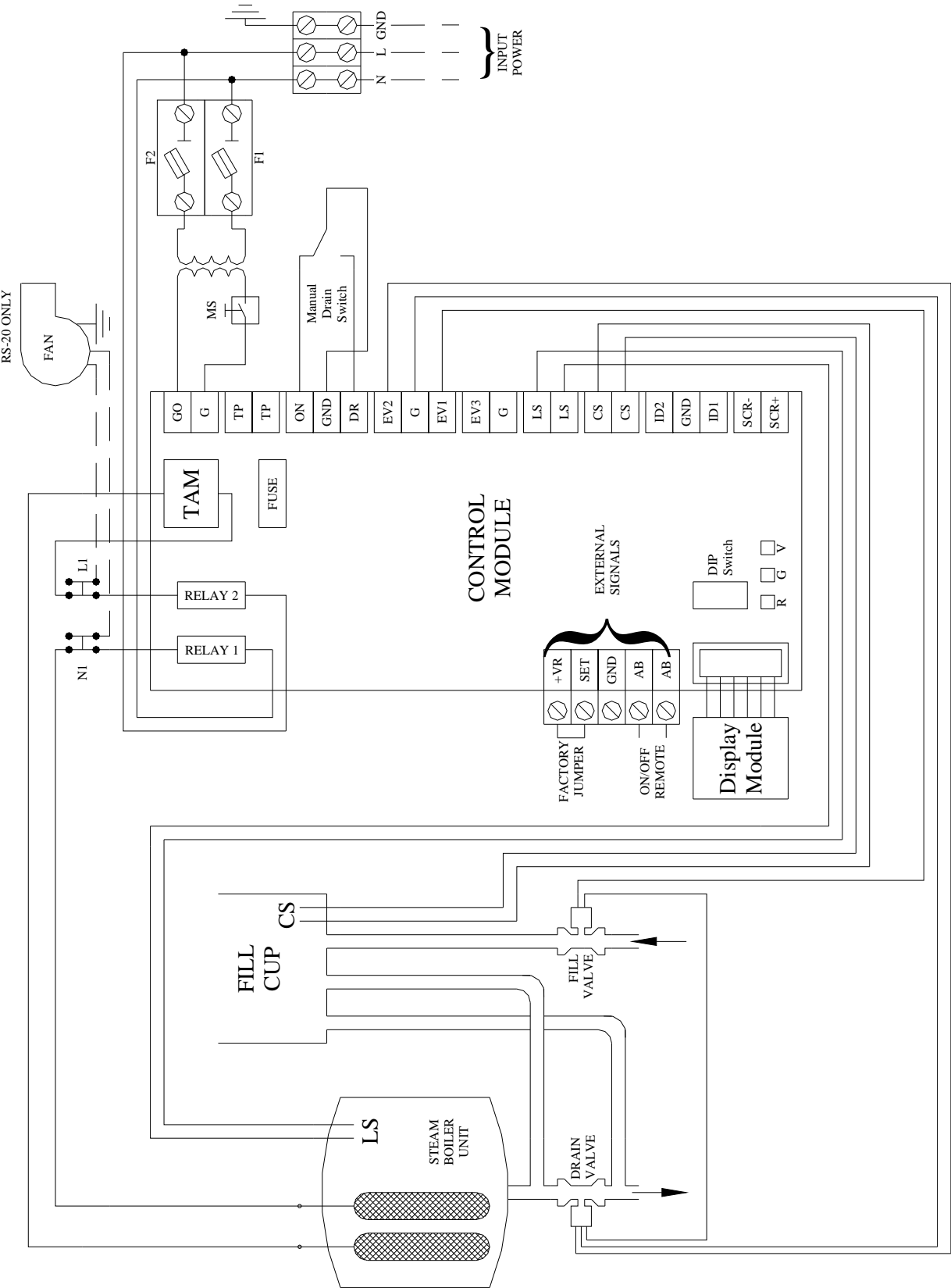

12. Technical Specifications

| Model | DS-20 Duct Kit | RS-20 Fan Kit |
|--|--|------------------|
| rated power supply voltage (Vac) | 230 | |
| steam connection (ϕ inches) | 7/8" | |
| steam outlet pressure limits (inches w.c.) | 0 to 8" w.c. | |
| operating conditions | temperature 34 to 104 °F, humidity 10 to 60% RH | |
| storage conditions | temperature 14 to 158 °F, humidity 5 to 95% RH noncondensing | |
| index of protection | IP20 | |
| auxiliary voltage / frequency (V - Hz) | 24 Vac, 50/60 Hz | |
| maximum auxiliary power (VA) | 25 VA | |
| instant steam production (1) (lbs/hr) | 7 lbs/hr | 7 lbs/hr |
| power consumed at rated voltage (kW) | 2.40 kW | 2.40 kW |
| duct steam nozzle | High temperature plastic | N/A |
| steam hose | High temperature EPDM | |
| water pressure | 15 to 150 psi | |
| water conductivity | 125 to 1250 micromhos | |
| room blower unit air volume | N/A | 100 CFM |
| room blower unit power consumption | N/A | 30 Watts |
| room blower unit noise level | N/A | 50 dBA |

(1) the average steam production is affected by factors such as: ambient temperature, water quality, steam distribution system

Dimensions and weights

| | | |
|--|----------|-----------|
| | A | 14-1/8" |
| | B | 10-1/4" |
| | C | 24-3/8" |
| | | |
| | packaged | 40 lbs. |
| | empty | 29.7 lbs. |
| | Wet * | 36.4 lbs. |

*: in normal operating conditions,
filled with water

| | |
|--------------------------|----------------------------|
| RS-20 (due to blower) | add 9" high add 10 lbs. |
|--------------------------|----------------------------|

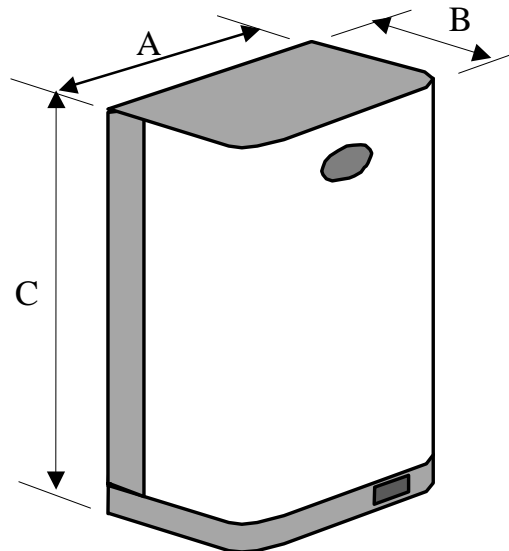

Installation, Operating and Maintenance Manual

LIMITED WARRANTY

The DS-20 and RS-20 humidifiers, if properly registered by the return of the attached warranty registration to General Filters, Inc., are warranted to the consumer against defects in materials and workmanship for a period of two years from the date of installation, so long as the product has been installed and operated in accordance with all appropriate manuals and wiring diagrams. Replacement or routinely replaceable parts such as steam cylinders and gaskets, are not covered by this limited warranty or any other warranties. Any other defective parts will be repaired without charge except for removal, reinstallation and transportation costs. To obtain repair service under this limited warranty, the consumer must send the defective part to General Filters, Inc.

THERE ARE NOT EXPRESS WARRANTIES COVERING THIS HUMIDIFIER OTHER THAN AS SET FORTH ABOVE. THE IMPLIED WARRANTIES OF MERCHANTABILITY AND FITNESS FOR A PARTICULAR PURPOSE ARE LIMITED IN DURATION TO TWO YEARS. THE MANUFACTURER ASSUMES NO LIABILITY IN CONNECTION WITH THE INSTALLATION OR USE OF THIS PRODUCT, EXCEPT AS STATED IN THE LIMITED WARRANTY. THE MANUFACTURER WILL IN NO EVENT BE LIABLE FOR INCIDENTAL OR CONSEQUENTIAL DAMAGES.

This limited warranty gives you specific legal rights, and you may also have other rights which vary from state to state. Some states do not allow either limitations on implied warranties, or exclusions from incidental or consequential damages, so the above exclusion and limitation may not apply to you.

Any questions pertaining to this limited warranty should be addressed to General Filters, Inc. General Filters, Inc. has elected not to make available the informal dispute settlement mechanism which is specified in the Magnuson-Moss Warranty Act.

General Filters, Inc.
43800 Grand River
Novi, MI 48375-1115
www.generalfilters.com

Canadian General Filters, Inc.
39 Crockford Blvd.
Scarborough, ON M1R 3B7
www.cgfproducts.com



Elite
Steam



General Filters, Inc.
43800 Grand River
Novi, MI 48375-1115
USA

WWW.GeneralAir.com

CGF Products
39 Crockford Blvd
Scarborough, ON M1R 3B7
CANADA

WWW.CGFProducts.com