

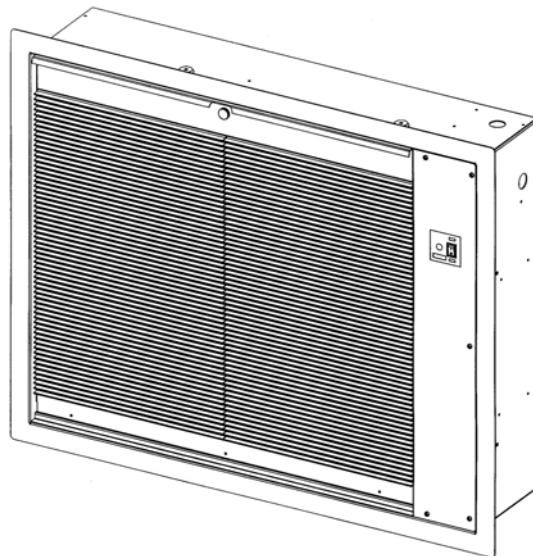

# OWNER'S MANUAL

## MODEL GA52F32 RETURN GRILLE MOUNT ELECTRONIC AIR CLEANER

*IMPORTANT: PLEASE READ MANUAL BEFORE OPERATING UNIT*



### Features

- Lifetime Filter System never needs replacing
- Electronically removes dust, mites, pollen, pet dander, tobacco smoke, cooking smoke and grease, mold, fungi, bacteria, and more down to 0.01 micron
- Light Weight Aluminum Collecting Cells are durable and easy to maintain
- Plastic Intake Grille is easy to wipe clean
- Hinged, Swing Out Door allows easy access to filters
- Automatic interlock switch disconnects power when unit is opened
- Durable Scratch-Resistant powder coat paint finish resists abrasion
- Electronic Air Proving Switch allows for quick wiring, and cycles Air Cleaner on/off with system fan
- Indicator Light shows Air Cleaner is working properly at a glance
- Easily installs on the wall or ceiling in the main return duct of a central forced air heating/cooling system

**IMPORTANT:** Please read entire instructions before installing, cleaning or repairing the Electronic Air Cleaner.

**CONTENTS**

SAFETY CONSIDERATIONS 2  
 WHAT THE ELECTRONIC AIR CLEANER DOES 2  
 BENEFITS 2  
 DESCRIPTION 2  
 HOW IT WORKS 2  
 MAJOR COMPONENTS 3  
 INSTALLATION 3-4  
 Location 3  
 Important Installation Notes 3  
 Installation 4  
 Wiring 4  
 SYSTEM CHECK 4  
 OPERATION 4  
 WHITE DUST 4  
 MAINTENANCE 4  
 Cell and Prefilter Cleaning 4  
 SERVICE 5-9  
 Testing Air Proving Switch (APS) 5  
 Adjusting The APS Sensor Depth 5  
 Replacing An Air Proving Switch (APS) 5  
 Testing For High Voltage At Power Board 5  
 Replacing Performance Light 6  
 Replacing A Power Board 6  
 Testing The 24 V Transformer 6  
 Replacing The 24 V Transformer 6  
 Testing Voltage Of Power Board 6  
 Testing Voltage At Cell 7  
 Setting Approximate Voltage Without High Voltage Meter 7  
 Testing Cell For Bad Contacts 7  
 Replacing A Tungsten Ionizing Wire 8  
 SPECIFICATIONS and DIMENSIONS 8  
 EXPLODED VIEW and PARTS LIST 9  
 TROUBLESHOOTING GUIDE 10  
 WARRANTY 11

**Certified for shock and electrical fire hazard only.**

**SAFETY CONSIDERATIONS**

Read and follow instructions carefully. Follow all local electrical codes during installation. All wiring must conform to local and national electrical codes. Improper wiring or installation may damage Air Cleaner.

Understand the signal words **WARNING** and **CAUTION** which are present in the Owner's Manual.

**WARNING** and **CAUTION** signifies a hazard which could result in property damage, personal injury or death.

**Installation and servicing of Electronic Air Cleaners can be hazardous. Only trained and qualified service personnel should install, repair, or service Electronic Air Cleaners.**

**WARNING**

Before beginning any installation or modification, be certain that the main line electrical disconnect switch is in **OFF** position. Electric shock could result. Tag disconnect switch with suitable warning labels.

**Homeowners or untrained personnel can perform the basic maintenance functions of cleaning and replacing filters.**

**When working on air cleaning equipment, observe precautions in the manual, labels attached to the unit, and other safety precautions that may apply. Follow all safety codes. Wear safety glasses and work gloves.**

**WHAT THE ELECTRONIC AIR CLEANER DOES**

Your High Efficiency Electronic Air Cleaner has been designed to remove atmospheric and household dust, coal dust, insecticide dust, mites, pollen, mold spores, fungi, bacteria, pet dander, cooking smoke and grease, tobacco smoke particles, and more down to 0.01 micron (0.01 micron = 1/2,540,000 of an inch).

**BENEFITS**

- Helps provide relief for allergy or asthma suffering.
- Helps prevent damaging black dust from staining walls and furnishings, reducing the amount of time and money spent cleaning and redecorating.
- Helps protect heating/cooling equipment, prolonging the operating efficiency.
- Improves indoor air quality for a healthier environment, year-round.

**DESCRIPTION**

The Electronic Air Cleaner is approximately 29 x 22 x 7 inches (73.6 x 55.9 x 17.8 cm). The unit is designed to be wall or ceiling mounted in the main return air duct of a forced air system. The intake grille is hinged to allow easy access to the collecting cells and prefilters. The unit is rated up to 2000 CFM (3398 m<sup>3</sup>/hr).

**HOW IT WORKS**

The High Efficiency Electronic Air Cleaner operates on the principle of electrostatic precipitation. Millions of airborne pollutants are carried through the return air duct of the heating/cooling system and treated through three stages of filtration.

The *prefilter* removes all large visible particles such as lint. Smaller particles then pass through to a *two-stage electrostatic collecting cell*. First, particles are given a powerful positive electrical charge by the ionizing wires.

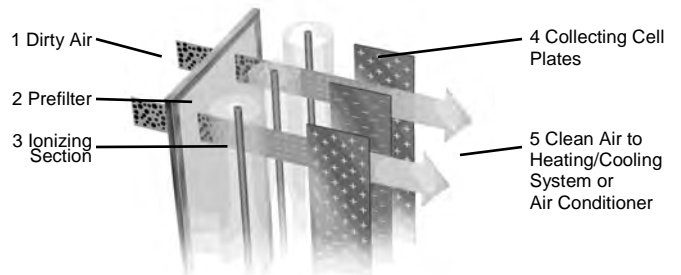

**Fig. 1**

Second, charged particles move into the collecting area where they are attracted to a series of grounded plates. Pollutants are held in this section like a magnet until washed away during cleaning.

## MAJOR COMPONENTS

### Cabinet

The cabinet is constructed of 18 gauge steel, painted with a tough powder-coated, scratch-resistant finish. Holes are provided to facilitate mounting to the ductwork. Access to the collecting cells and prefilters is through a hinged door.

The access door is interlocked to cut power to the unit when opened.

### Prefilters

The washable prefilters, measuring 11½ x 20 inches (29.21 x 50.8 cm) are constructed of multi-layers of aluminum mesh for maximum filtration of large particles.

### Collecting Cells

The dual voltage collecting cells are constructed of heavy gauge aluminum to resist rust and damage. The first stage, the ionizing section, is charged at approximately 7000 VDC. The collecting plates are alternately grounded and charged at 4600 VDC. The arrow on the cells indicates the direction of air flow which must point toward the rear of the unit.

### Electrical Compartment

The electrical compartment contains the system switch, safety interlock, high voltage power board, transformer, air proving switch and performance indicator light.

## INSTALLATION

### Location

The Air Cleaner should be installed to the return air duct in the living area of the home or office. It can be installed either in a wall or ceiling, but not in the floor. This unit will replace the existing return air grille currently

installed to the main return duct. For the unit to perform properly, all the return air must pass through the Electronic Air Cleaner.

**In a wall installation, the unit must be installed with the hinge down.**

The return duct or transition should end slightly behind the finished wall or framing. It should be approximately 1/4 -1/2 inch (.63 - 1.27 cm) larger than the Air Cleaner to allow the back of the unit to slip into the duct when installing.

When the air duct does not fit the Air Cleaner opening, a gradual transition is recommended to reduce air turbulence through the Air Cleaner and to increase its efficiency. There should not be more than 20° of expansion used for the transition fitting.

### Important Installation Notes

When installing this Air Cleaner, it is important that there is adequate air flow over the Air Proving Switch (APS) sensor to activate the power supply when the fan is operating. To ensure the flow of air over the sensor, the attached ducting and transition to the Air Cleaner must be sized and positioned correctly.

If rectangular duct is fitted to the back of the unit, it must be placed so the opening is over the APS sensor or transitioned deep enough to ensure air flow over the sensor.

If round duct is used, it must be positioned over the center of the opening in the back of the Air Cleaner and should be at least 18" diameter. (See Fig. 2) If the connecting duct back to the furnace or air handler is smaller, a reducing collar should be used down the line to reduce the duct to the required size. If the duct opening at the rear of the Air Cleaner needs to be off-set because of installation restrictions, it must be off-set so that the position of the air opening is closer to the APS sensor.

With a round duct or under sized rectangular duct it is important that the transition area between the back of the Air Cleaner and the bottom of the duct opening is maintained. A transition height of 10" will allow proper flow across the sensor. (See Fig. 3)

The APS sensor can be adjusted further into the air stream. This may be required if the APS sensor is not directly in the air stream and a multi-speed or variable

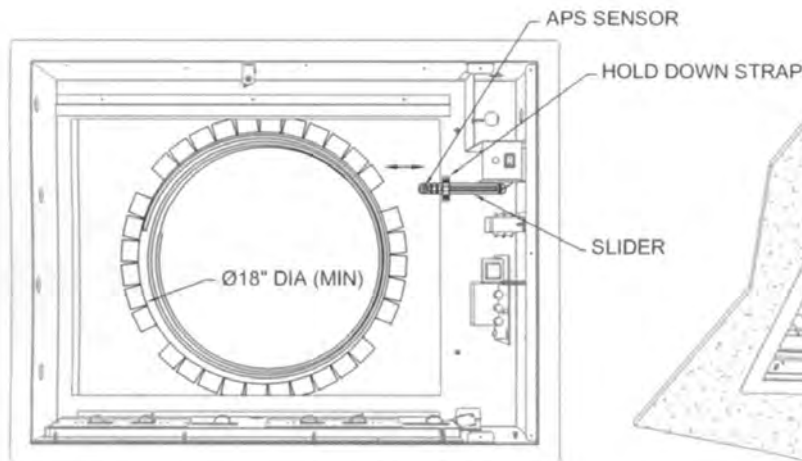

Fig. 2

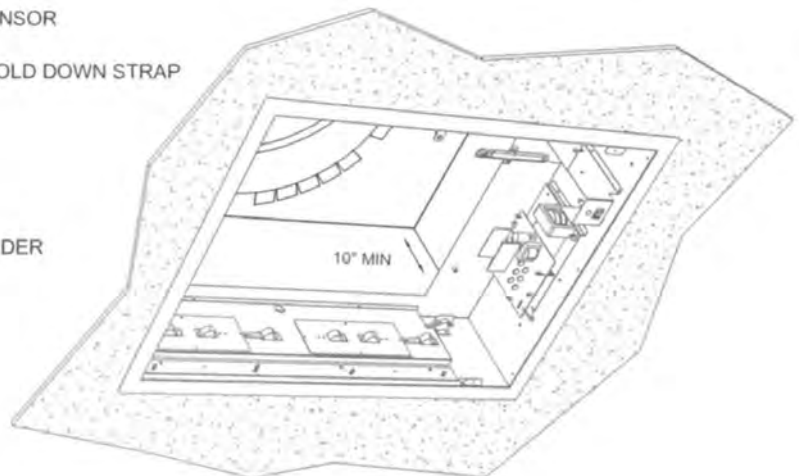

Fig. 3

speed motor drops the air flow to a point the sensor will not activate the power board.

## Installation

Carefully remove the Air Cleaner from the carton. Remove the cells and prefilters from the unit. Remove the access door from the unit by removing the screw on the end of the retaining link in the enclosure. Lower the access door and remove the nuts securing the hinge to the enclosure.

Remove the screws securing the electrical compartment cover.

The hole in wall or ceiling should be made to fit the Air Cleaner opening as closely as possible. The opening should be framed to provide adequate support for the Air Cleaner. Before mounting the Air Cleaner, cover the framing and close the opening to within 1/4 in. (.63 cm) of the dimension of the rear of the enclosure of the Air Cleaner. Match the finish to the existing wall.

Mount the Air Cleaner into the framed hole and slide into the duct until the front flange is flush with the wall. Secure the Air Cleaner to the frame using sheet metal screws. Do not overtighten screws as this may distort the enclosure. Once the unit is secured to the wall, the access door and retaining link can be replaced.

## Wiring

Wiring should only be performed by qualified personnel only. All wiring must comply with all applicable codes and standards. The voltage of the power source must match the voltage indicated on the Air Cleaner. The Air Cleaner should operate ONLY when the system fan is running. Make sure the Air Cleaner is properly grounded.

### WARNING

Electrical shock can cause injury or death. Be certain main line disconnect switch is off before wiring.

Wire the Air Cleaner directly to the power source. The APS will power the Air Cleaner when there is sufficient airflow to activate the sensor.

Connect the black lead of the Air Cleaner to the line side of power source. Connect the white lead to the neutral side of the power source. Connect the green lead to ground. **See Fig. 5.**

## SYSTEM CHECK

Perform the following system check before operation.

1. Replace the prefilters and collecting cells. Close access door and replace thumb screw.
2. Turn Air Cleaner power switch **ON**. Ensure system fan is operating. The performance indicator light should be lit showing that the Air Cleaner is operating.

**Note:** There may be some arcing or snapping sounds from the collecting cells. This is normal when the unit is new. In about 2 weeks, as the sharp edges of the cells become smoother, the arcing will disappear.

## OPERATION

The Air Cleaner will run as long as there is airflow

through the ducts. The Air Cleaner will not run if the system fan is off. For proper operation, follow these simple steps:

1. Run heating/cooling system fan continuously, and on low speed if available.
2. Remove any furniture which may block the return air grille, so that air moves freely to the furnace/ air conditioner.
3. Check for proper operation of the system fan.

## WHITE DUST

After installation of the Air Cleaner, you may notice some white dust on tabletops and shelves. Most large particles such as lint, are too heavy to remain airborne and tend to settle quickly, never reaching the Air Cleaner.

This white visible dust is normally referred to as "clean dust." As the Air Cleaner is removing the dark and staining particles from the air, the lint will also be cleaner.

Lint dust is most noticeable on dark furnishings; in homes containing new carpeting; and where there is a lot of household traffic from occupants and pets. To reduce lint dust, use continuous fan operation and keep return vents unrestricted to create an efficient airflow.

**Note:** The Air Cleaner does NOT produce more lint or dust.

## MAINTENANCE

It is important to follow a scheduled maintenance for maximum performance of the Air Cleaner.

### CAUTION

Damage to cells may occur if improperly handled or washed. Do not wash cells in a dishwasher. Never use any object to clean between the cell plates, as this may cause damage to plates or ionizing wires. Never place cell in oven to dry. The edges of the cell may be sharp - handle with care.

## Cell And Prefilter Cleaning

The collecting cells and prefilters must be cleaned on a regular basis for the Air Cleaner to function at its peak efficiency. The frequency of cleaning will vary from one location to another. On average, the cells should be cleaned every 3 months.

1. Turn **OFF** power switch and wait 15 seconds. Open access door and remove collecting cells and prefilters. **In a ceiling application open the door carefully.**
2. Place cells in a laundry tub. Rinse with hot water and spray completely with DAX Detergent (or a non-chlorine, non-corrosive, non-abrasive liquid household detergent.) Allow detergent to run down both sides of plates and ionizing wires. Let stand for 5 minutes and rinse with hot water. Repeat process three times.
3. Rinse cells well with hot water (maximum 120°F/49°C).
4. If dirt remains, let cells soak in a solution of DAX Detergent and hot water for 30-60 minutes, then rinse.
5. Tilt cells on 45° angle on their short side, with arrows pointing sideways. Allow to dry completely,

approximately 12-24 hours. A hair dryer may be used to speed up drying time.

6. To wash prefilters, spray with DAX Detergent, rinse and let dry. Do not wash in the same water as collecting cells.
7. Place cells and prefilters back into cabinet. Close door and turn power switch **ON**. If the performance light does not come on or arcing occurs, turn Air Cleaner **OFF** and allow air from system fan to dry cells completely.



**Fig. 4 — DAX Detergent is available from your installer or dealer.**

## SERVICE

### WARNING

Electronic Air Cleaners use high voltage (low amperage). Only trained personnel should perform service. Use caution. Electric shock can cause injury or death. Disconnect power source before replacing parts.

## Testing Air Proving Switch (APS)

The APS sensor must protrude into the airstream to work effectively. The sensor is very sensitive and operation may be affected by cold temperatures, an air exchanger, or a fresh air duct connected to the cold air return near the Air Cleaner.

The APS uses a Triac in its output circuit, which affects the voltage sine wave. Using a regular digital voltmeter will give a false reading. To check the output from the APS, use a true RMS (root mean square) meter to measure the output at terminals 1 and 4 of the APS. The output should be between 105 and 115 VAC, depending on the airflow across the sensor.

A 125 volt neon lamp may be used to test the output of the APS. Place the leads of the lamp across terminals 1 and 4 of the APS. If the lamp lights, the voltage is sufficient for proper operation.

When the Air Cleaner is turned on without airflow, the APS sensor heats up and within 30 seconds, opens the circuit to turn off the power board. When the fan starts up (the sensor is cooled), the circuit will close, the power board is turned on, and the performance light will come on.

If the power board fails to come on with the fan on, check that the sensor is properly set in the airstream behind the cell next to the switch. To check the APS for

proper operation, turn the unit on and activate. The power board should come on immediately, and then turn off within 30 seconds as the sensor heats up. When the system fan is turned on, this should activate the power board within 10 seconds. Service the sensor carefully. The sensor leads are 120 V.

## Adjusting the APS Sensor Depth

Turn the power switch **OFF** and wait 15 seconds then open the door to the collecting cells. Remove the cells and prefilters. Loosen the two screws on the hold down strap and pull out on the slide mechanism. (**See Fig. 2**) Do not pull on the sensor!

Once the sensor is in the desired position tighten the two screws on the hold down strap. Replace the cells and prefilters and test the unit for activation on all air speeds.

## Replacing An Air Proving Switch (APS)

Before replacing the APS, turn the power to the Air Cleaner **OFF** at the source.

1. Disconnect wiring from terminals 1, 2, 3, and 4 on the APS.
2. Release circuit board from plastic spacers by pinching end of spacer and pulling board out.
3. Remove hold down strap of the slider.
4. Install new APS on plastic spacers.
5. Install slider hold down strap loosely and adjust sensor to desired position in the air flow. Tighten strap.
6. Connect wiring to terminals on APS. Wiring from power source is connected to terminals 2 and 3. Wiring to the transformer is connected to terminals 1 and 4.
7. Test the new APS.

## Testing For High Voltage At Power Board

A high voltage meter capable of measuring up to 10,000 VDC is required to test the voltage.

1. Turn the Air Cleaner **OFF**. Remove cover from electrical compartment.
2. The Air Cleaner should be **ON** with the door closed. The unit fan should be running. The Air Cleaner should be on at least 5 minutes to allow voltage to stabilize.
3. Connect the ground of the high voltage meter to the ground stud of the power board.
4. Check terminals HV1 and HV2 on the power board to determine if voltage is present.
5. If no voltage is present, remove both cells from the Air Cleaner and close access door.
  - a. Check the voltage at HV1 and HV2 again.
  - b. If voltage is present, the problem is with one of the cells or the copper contact on the high voltage tray.
  - c. With a flashlight, look into the cabinet to check condition of the copper contacts.
  - d. If the contacts are not bent, replace one cell and retest voltage. If cell is OK, test the other cell. If the problem is with a cell, see Troubleshooting

- Guide.
- e. Check the APS to make sure that it is functioning correctly.
  - f. Check the transformer to make sure power is being supplied to the power board.
6. If there is voltage present, but the performance light does not come on, replace light.
  7. High voltage can be adjusted with high voltage potentiometer if required.

### Replacing Performance Light

Before replacing power board, turn power to the Air Cleaner **OFF** at the source.

1. Remove the electrical compartment cover.
2. Disconnect the performance light wiring connected to the terminals on the LED.
3. Push the light out through front of the switch bracket.
4. Push the new light into the bracket.
5. Connect the wiring to the LED terminals. The leads are polarity sensitive. The yellow lead goes on the terminal with the red mark.
6. Replace cover.
7. Return power to Air Cleaner. Test light.

### Replacing A Power Board

Before replacing power board, turn power to the Air Cleaner **OFF** at the source.

1. Remove the electrical compartment cover.
2. Disconnect wiring from the LED, HV1, HV2 and 24 V terminals. Note which terminals the wires belong.
3. Remove the hex nut from the power board.
4. Release the power board from the 3 plastic board spacers, by pinching the end of the spacers and pulling the board out.
5. Push new board onto spacers. Make sure spacers click into place to hold down board.
6. Screw on the hex nut saved from Step 3. Ensure the star washer is in place over the steel spacer for proper grounding.
7. Reconnect wiring to LED, HV1, HV2, and 24 V terminals on the new power board.
8. Replace electrical compartment cover.
9. Return power to Air Cleaner. Test power board.

**Note:** Although the power board has been set before shipping, it may be necessary to reset the voltage to the correct load for optimum efficiency. Refer to Testing Voltage At Power Board section for more information.

### Testing The 24 V Transformer

1. The Air Cleaner should be **OFF**. The system fan should be running. The access door should be closed.
2. Remove electrical compartment cover.
3. Disconnect the leads of the 24 V transformer from the power board.
4. Turn the Air Cleaner **ON**. Measure voltage across leads with a voltmeter. Voltage should read 24 - 28 VAC.

5. If no voltage present, check operation of the APS.
6. Before replacing the transformer, check the resistance across the power board 24 V input terminals, without the transformer connected. Resistance should read above 20K ohms with an analog meter and above 4M ohms with a digital meter. If the resistance readings are below these values, the power board may be the cause of the transformer failure.
7. Reconnect leads to power board.
8. Replace electrical compartment cover.

### Replacing The 24 V Transformer

Before replacing 24 V transformer, turn power to the Air Cleaner **OFF** at the source.

1. Remove electrical compartment cover.
2. Disconnect the secondary leads from the transformer to the 24 V terminals on the power board.
3. Cut the primary leads (to the APS) close to the transformer.
4. Remove the 2 hex head nuts from the transformer mounting studs.
5. Remove transformer.
6. Place new transformer over studs and re-install 2 hex head nuts to secure into place.
7. Connect secondary leads (white) to the 24 V terminals on the power board.
8. Wire nut primary leads from APS (cut in Step 3) to primary leads from transformer.
9. Replace electrical compartment cover.
10. Turn on power to the Air Cleaner and test.

### Testing Voltage Of Power Board

Voltage on the power board may drop below required level when installation area is too damp, too cold, or if the humidity is too high. Voltage on power board may be too high when installation area is too dry or too hot, or home is in close proximity to hydro towers or situated in remote farm land areas. By adjusting the HV ADJ potentiometer, the voltage can be set to optimum level. A high voltage meter capable of measuring 10,000 VDC is required. To test and adjust voltage level, perform the following procedure:

1. Turn the Air Cleaner **OFF**.
2. Remove the electrical compartment cover.
3. Connect the ground of the high voltage meter to the ground stud of the power board.
4. Turn **ON** the Air Cleaner and wait 5 minutes before checking voltages to allow voltages on cells to stabilize.
5. Measure the voltages at HV1 and HV2 on the power board.
6. Adjust the HV ADJ potentiometer until the voltage reading matches the voltage in Table 1.

Model	Maximum Voltages on Plates (KVDC)	Maximum Voltage on Ionizer (KVDC)
GA52F32	4.6 - 4.8 (HV1)	7.0 - 7.3 (HV2)

**Table 1 — Power Board Voltage Settings**

7. Turn **OFF** the Air Cleaner.
8. Remove the high voltage meter.
9. Replace the electrical compartment cover.
10. Turn **ON** the Air Cleaner.

### Testing Voltage At Cell

1. Turn **OFF** power switch. Open access door to Air Cleaner. Remove prefilters from track.
2. Close access door to Air Cleaner. Remove one of the grilles from in front of each cell.
3. Remove the electrical compartment cover.
4. Attach the ground of the high voltage meter on to a grounded area of the cell.
5. Place the tip of the high voltage probe on the cell wire.
6. Turn the Air Cleaner **ON**.
7. Wait until the voltage stabilizes, then take a reading. Adjust the HV ADJ potentiometer until the voltage reading matches the voltage in Table 1. If the voltage fails to stabilize or jumps up and down by more than 100 V, there may be a bad contact in the cell or a bad contact between the cell contacts and the high voltage contacts on the contact tray.
8. Test the voltage in both cells. They should read very close to the same voltage.
9. Turn the Air Cleaner **OFF**. Replace the grilles, electrical cover and prefilters.
10. Turn the Air Cleaner **ON**.

### Setting Approximate Voltage Without High Voltage Meter

A high voltage meter should be used. If one is not available, this method can be used. This will only set an approximate voltage. After using this method, the voltage should be reset with a high voltage meter as soon as possible.

1. Remove electrical compartment cover.
2. Turn the HV ADJ potentiometer fully counter-clockwise. Air Cleaner may arc or snap at this point.
3. Turn the HV ADJ potentiometer clockwise slowly until the arcing and snapping stops.
4. Replace electrical compartment cover.

### Testing Cell For Bad Contacts

1. Turn **OFF** power switch. Open access door to Air Cleaner. Remove prefilters from track.
2. Close access door to Air Cleaner. Remove one of the grilles from in front of each cell.
3. Turn the Air Cleaner **ON**.
4. Place a screwdriver between plates of the cell. There should be an initial snap when the plates are shorted, then no sound. If a hissing or ticking occurs, then there is a bad contact either between the cell and the high voltage contact or the contacts within the cell.
5. Test the ionizing wires by the same method, shorting the wire to the grounded extended plate of the cell.
6. Turn the Air Cleaner **OFF**. Remove the cells and check to see if the copper contacts along the bottom of the cell channel are free.
7. With an ohmmeter, check continuity between the top, outside disc contact and the first plate on the opposite side of the cell. The reading should be close to 0 ohms. If not, bend the contact to touch the plate.

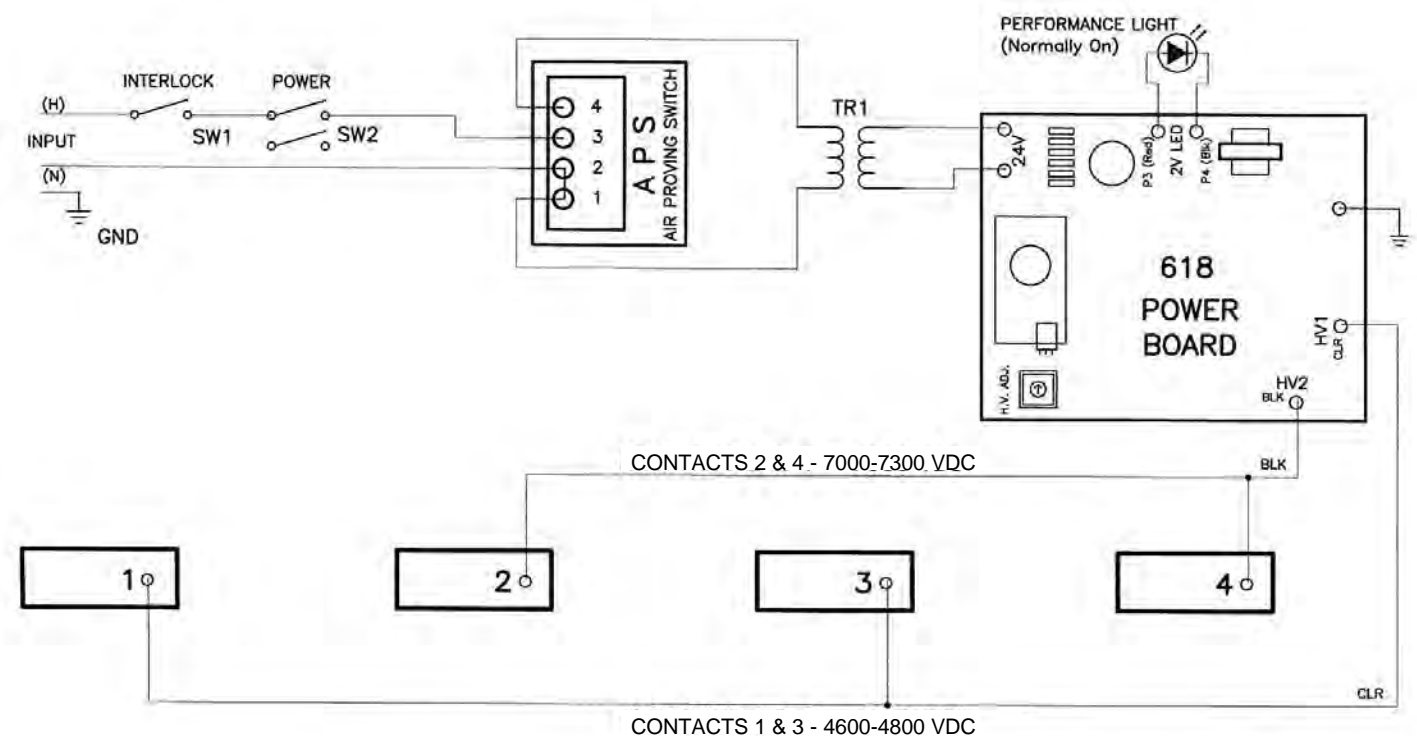

Fig. 5 — Schematic

8. With an ohmmeter, check continuity between the top, center disc contact and one of the ionizing wires. The reading should be close to 0 ohms. If not, bend the contact to touch the ionizing bar.
9. Replace grilles, prefilters and cells. Turn **ON** the Air Cleaner.

### Replacing A Tungsten Ionizing Wire

Replacement wires are cut to the correct length and have eyelets at each end for easy replacement.

1. Turn **OFF** power to Air Cleaner.
2. Remove cell from Air Cleaner.
3. Remove all parts of broken wire, as well as spring and S-hook. If necessary, cell may be used temporarily with one wire missing until a replacement is received.
4. Using needle-nose pliers, place spring hook in the hole of the ionizing bar near cell top.
5. Place eyelet of wire over the S-hook and place S-hook into hole on ionizing bar on other side of cell. Keep wire tight to ensure S-hook remains in hole.
6. Using the needle-nose pliers, grab the end of the spring and stretch towards loop in wire. Place eyelet in wire over spring hook and release spring. **See Fig 6.**
7. Install cell in Air Cleaner.
8. Return power to Air Cleaner.
9. Test cell for proper operation.

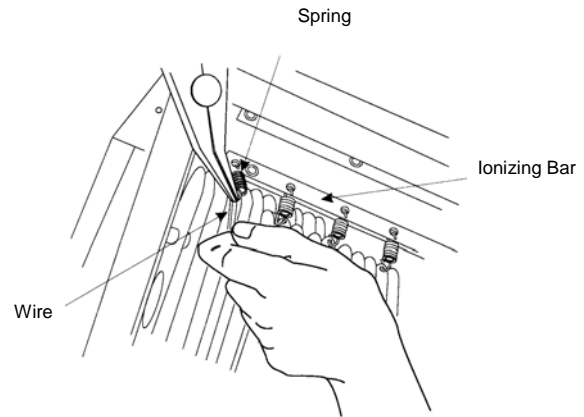

**Fig. 6 — Replacing An Ionizing Wire**

<b>MODEL</b>	<b>GA52F32</b>
<b>HOUSE SIZE</b>	n/a
<b>AIR FLOW</b>	up to 2000 cfm
<b>DUCT SIZE</b>	22 x 29.1 in
<b>CABINET DIMENSIONS</b>	31.4 x 24.4 x 7 inches
<b>WEIGHT</b>	38 lbs
<b>POWER</b>	120 v 60 hz

**Table 2 — Specifications**

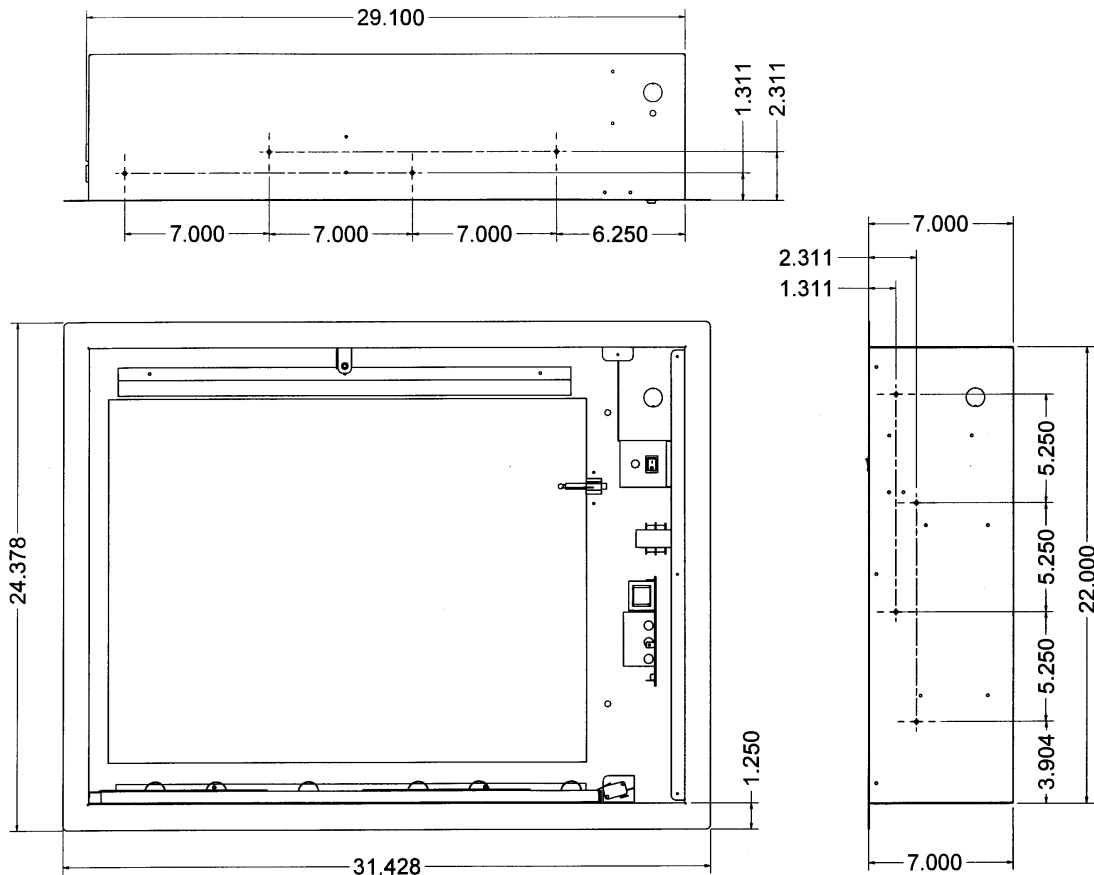

**Fig. 7 — Dimensions**



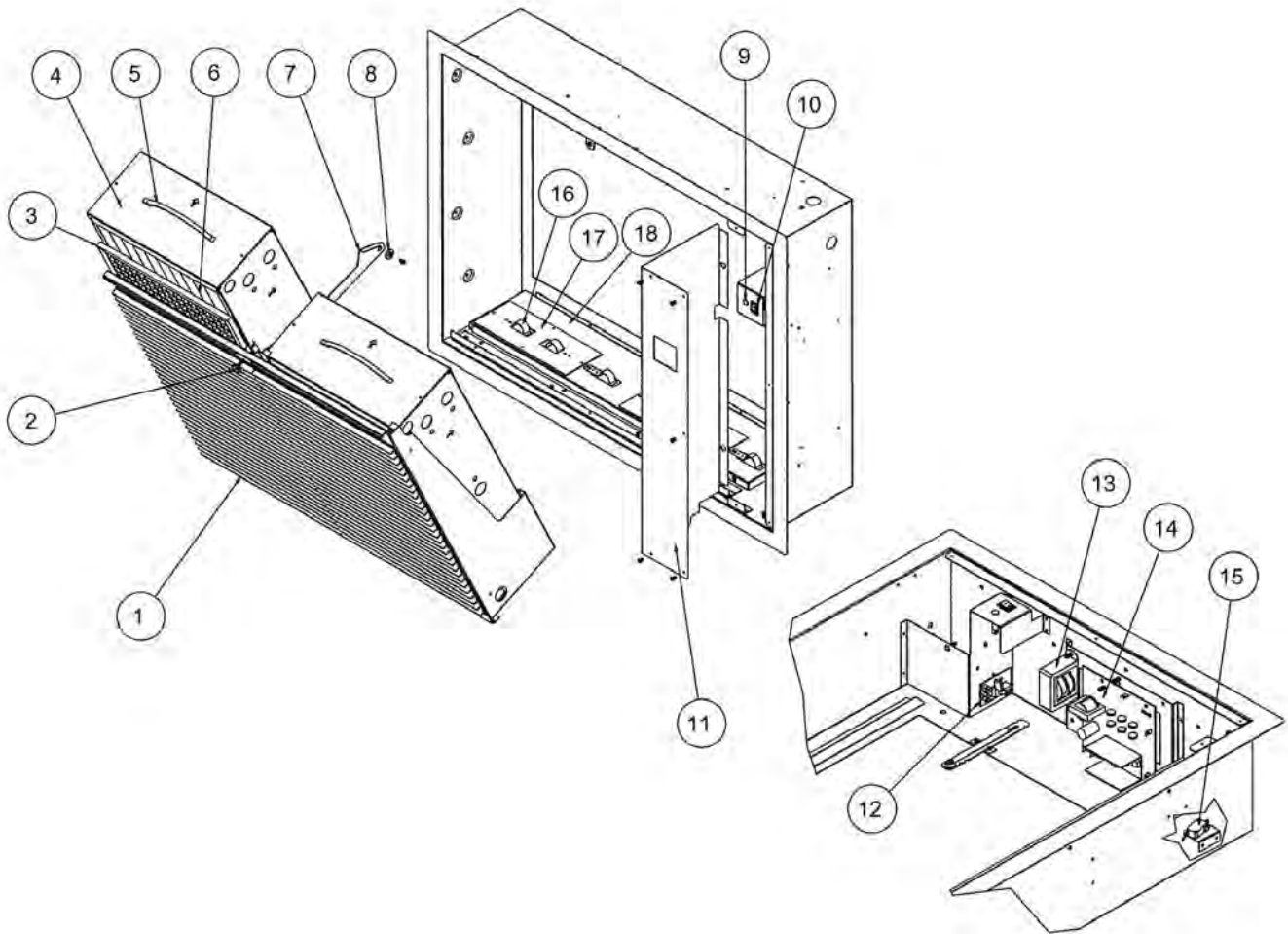

**Fig. 8 — Exploded View and Parts List**

#	Description	Part Number
1	Front Grill	EACGM-01
2	Thumb Screw	EACGM-02
3	Prefilter	EACGM-03
4	Collecting Cell	EACGM-04
5	Cell Handle	EAC14-16
6	Ionizing Wire (with Spring & Hook)	EACGM-06
7	Door Link Assembly	EACGM-07
8	Door Link Bushing and Screw	EACGM-08
9	Power Switch	EACGM-09
10	Green Indicator Light	EACGM-10

#	Description	Part Number
11	Electrical Cover	EACGM-11
12	Air Switch Assembly with Slider	EACGM-12
13	24 Volt Transformer	EACGM-13
14	Power Board	EACGM-14
15	Safety Interlock Switch	EAC14-02
16	Copper Contact	EAC14-08
17	Fibreboard (with 2 Copper Contacts)	EACGM-17
18	High Voltage Contact Tray (Complete)	EACGM-18
19	Door Label (Before Cleaning...)	EACGM-19
20	Dax Detergent	9900

Use the diagram above to identify the part which is required. To order parts call the number listed below or call your local contractor.



**General Filters, Inc.**  
 43800 Grand River Ave.  
 Novi, Michigan 48375-1115  
 WWW.GENERALAir.COM  
 1-866-476-5101  
 248-476-5100

**Canadian General Filters, Ltd.**  
 39 Crockford Blvd.  
 Scarborough, Ontario  
 WWW.CGFPRODUCTS.COM  
 416-757-3691



**Table 3 — TROUBLESHOOTING GUIDE**

<b>PROBLEM</b>	<b>PROBABLE CAUSE</b>	<b>REMEDY</b>
<b>Unit does not function correctly. Power switch on and performance indicator light is off.</b>  <b>(Insure system fan is on high speed)</b>	System fan is not on.	Turn system fan on.
	Wiring improperly connected.	Check wiring.
	Defective power switch.	Check power switch for continuity with multimeter. Replace if defective.
	Defective safety interlock.	Check interlock switch for continuity with multimeter. Replace if defective.
	Power (120 V) is not provided to device.	Check power wiring with multimeter.
	Short in cells due to: 1. Broken ionizing wire(s). 2. Large particles wedged between cell plate(s). 3. Cells washed recently and are still wet. 4. Cell insulator is dirty or damaged. 5. Cell plate(s) are bent.	1. Remove wire or wire fragments, spring and S-hook. Replace. 2. Shake large particles out or wash cell. 3. Allow cells to dry completely. 4. Clean or replace cell insulator. 5. Straighten plates with pliers.
	Defective performance indicator light.	Determine whether high voltage is present by testing power board. If present, replace indicator light.
	Defective power board.	With the cells out, check components ahead of power board. Adjust high voltage potentiometer on power board. If high voltage is not present, replace power board.
	Air Proving Switch is not getting enough air across the sensor.	Check that the APS sensor is located far enough into the air stream to activate it on all speeds. Adjust the slider so the sensor is located further into the air stream. Ensure there is a minimum of 360 CFM of air to the Air Cleaner.
	Air Proving Switch (APS) sensor is burnt out.	Jumper 3 & 4 on APS, close door. If light comes on, replace APS.
Off board 24 V transformer is not working.	Verify output of transformer. Replace if necessary.	
<b>Cell makes loud hissing noise or causes radio interference.</b>	Internal cell contacts are not touching plates.	Test contacts and repair.
	Copper contacts on high voltage tray not making good connection on cell.	With needle-nose pliers, gently pull contacts up or replace contacts.
<b>Cells arcing excessively (power switch on and performance indicator light on).</b>	Cells wet from washing.	Allow cells to dry completely.
	Particle(s) lodged in cell or broken ionizing wire.	Wash cell. Shake particle out of cell. Replace wire, if necessary.
	Ducts were not cleaned prior to installation of Air Cleaner.	Clean ducts.
	Cell plate(s) are bent.	Remove cells and adjust to original spacing using needle-nose pliers.
	Voltage is too high.	Adjust high voltage potentiometer on power board clockwise.
<b>Cells arcing excessively at bottom of cell near copper contacts (power switch on and performance indicator light on).</b>	Contacts on high voltage tray are broken or bent.	If possible, pull up contacts with needle-nose pliers or remove high voltage tray and replace contacts.
<b>Cells not collecting dirt (power switch on and performance indicator light on).</b>	Arrow on cell(s) not pointing towards back.	Reposition cells.
	System fan is on "Automatic" setting (Air Cleaner not on continuously)	Use "Fan On" system fan setting for continuous fan operation.
	Not enough voltage on collecting cells.	Adjust high voltage potentiometer counter-clockwise on power board.
<b>Ozone odor</b>	Cell plate(s) are bent.	Straighten with needle-nose pliers.
	Loose or broken ionizing wire(s).	Replace wires.
	Dirty cells.	Wash cells.
	Air Cleaner is on when system fan is not running. Air switch not activated or Air Cleaner wired incorrectly.	Check operation and wiring of air switch and Air Cleaner.
	Incoming voltage is higher than 120 V.	Adjust high voltage potentiometer clockwise on power board.
	Air Cleaner is oversized for house. Not enough airflow to cover surface area of cells.	Use correct size of Air Cleaner.
	Home is extremely dry.	Repair or install central humidifier.
<b>White dust</b>	Clean lint dust too heavy to remain airborne.	Keep fan running continuously. Ensure that return air grilles are not obstructed. See page 4 for more information.

## **ELECTRONIC AIR CLEANER LIMITED FIVE YEAR WARRANTY**

Electronic Air Cleaners, if properly registered by the return of the attached warranty registration to General Filters, Inc., are warranted to the consumer against defects in materials and workmanship for a period of five years from the date of installation, so long as the product has been installed and operated in accordance with all appropriate manuals and wiring diagrams. Replacement or routinely replaceable parts such as prefilters, are not covered by this limited warranty or any other warranties. Any other defective parts will be repaired without charge except for removal, reinstallation and transportation costs. To obtain repair service under this limited warranty, the consumer must send the defective part to General Filters, Inc.

THERE ARE NOT EXPRESS WARRANTIES COVERING THIS ELECTRONIC AIR CLEANER OTHER THAN AS SET FORTH ABOVE. THE IMPLIED WARRANTIES OF MERCHANTABILITY AND FITNESS FOR A PARTICULAR PURPOSE ARE EXPRESSLY EXCLUDED. THE MANUFACTURER ASSUMES NO LIABILITY IN CONNECTION WITH THE INSTALLATION OR USE OF THIS PRODUCT, EXCEPT AS STATED IN THE LIMITED WARRANTY. THE MANUFACTURER WILL IN NO EVENT BE LIABLE FOR INCIDENTAL OR CONSEQUENTIAL DAMAGES.

This limited warranty gives you specific legal rights, and you may also have other rights which vary from state to state. Some states do not allow either limitations on implied warranties, or exclusions from incidental or consequential damages, so the above exclusion and limitation may not apply to you.

Any questions pertaining to this limited warranty should be addressed to General Filters, Inc. General Filters, Inc. has elected not to make available the informal dispute settlement mechanism which is specified in the Magnuson-Moss Warranty Act.

Agency:
---------

Form 14453 Rev. A



**General Filters, Inc.**  
43800 Grand River Ave.  
Novi, Michigan 48375-1115  
[WWW.GENERALAIR.COM](http://WWW.GENERALAIR.COM)

**Canadian General Filters, Ltd.**  
39 Crockford Blvd.  
Scarborough, Ontario  
[WWW.CGFPRODUCTS.COM](http://WWW.CGFPRODUCTS.COM)



**Technical Support 1-800-267-8305**



# ATTENTION INSTALLER



## IMPORTANT WIRING INFORMATION

This Electronic Air Cleaner is equipped with an Air Proving Switch (APS). The recommended source for the input voltage to the Air Cleaner is from the same source that is supplying the heating/cooling equipment, providing it is the same voltage as the Air Cleaner. The Air Cleaner should be wired directly to the power source. The APS will power the Air Cleaner when there is sufficient airflow to activate the sensor.

If you wish to wire the Air Cleaner to the EAC / Accessories Module on the circuit board of the furnace or air handler, ensure that there is 115 Volt output from these terminals, when the unit is run manually and is running on low speed. Some manufacturers do not supply full output voltage to the terminals in the low speed mode, so the Air Cleaner will not function. The green Performance Indicator Light will not turn on.

The Air Cleaner performs best when the system fan is on “FAN ON” or “Continuous” mode, and is run on the low speed. Check the output of the terminals with a volt meter when running on low speed, before wiring the Air Cleaner to the circuit board.

**The Air Cleaner must be wired to operate only when the system fan is on.**

**See page 4 of the Owner’s Manual for more information on wiring.**



**See page 3 for Important Installation Notes before installing.**